

Dimension Drawing

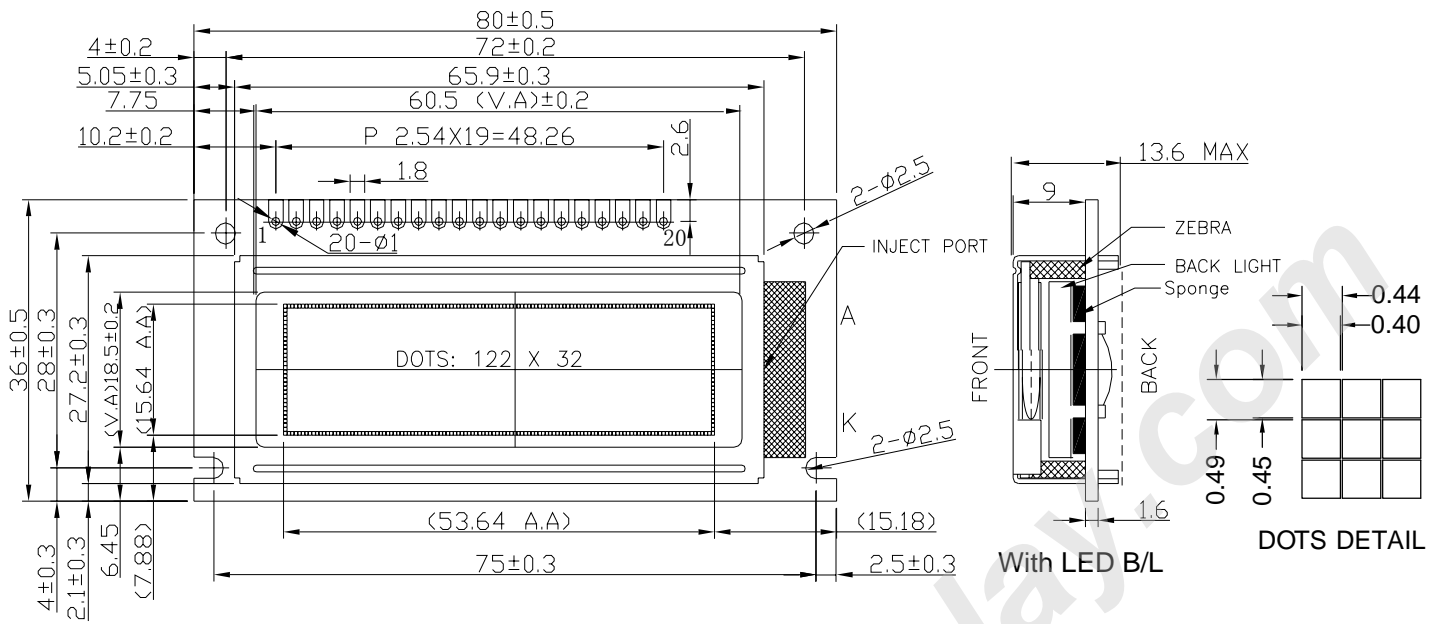

TOLERANCES UNLESS OTHERWISE STATED
 X.X ±0.20 X.XX ±0.10 UNIT: mm

Feature:

1. 122 x 32 dots graphic display
2. Built-in controller(SBN1661G or equivalent)
3. +5V power supply(also available for +3.3V)
4. 1/32 Duty cycle
5. STN or FSTN Mode
6. Match all kind colors of LED back light
7. ROHS compliant

Mechanical Data

Item	Standard	Unit
Module dimension	80.0 x 36.0	mm
Viewing area	60.5 x 18.5	mm
Mounting hole	72.0 x 28.0	mm
Dots size	0.4 x 0.45	mm

Interface Pin Connections

PIN NO.	Symbol	Function
1	VSS	GND
2	VDD	+5V or +3.3V
3	V0	Contrast adjustment
4	A0	H → Data L → Instruction
5	CS1	L → Chip1 Enable
6	CS2	L → Chip2 Enable
7	NC/CL	NC or External clock 2KHz
8	NC/E	NC or Enable signal
9	R/W	H :Read data L :Write data
10	DB0	H/L Data bus line
11	DB1	H/L Data bus line
12	DB2	H/L Data bus line
13	DB3	H/L Data bus line
14	DB4	H/L Data bus line
15	DB5	H/L Data bus line
16	DB6	H/L Data bus line
17	DB7	H/L Data bus line
18	REST	H → L Rest the LCM
19	A	Power supply for B/L(LED+)
20	K	Power supply for B/L(LED-)

Absolute Maximum Rating

Item	Symbol	Standard			Unit
		Min	Typ	Max	
Power supply	VDD-VSS	-0.3	---	7.0	V
Input voltage	VI	-0.3	---	VDD	

Electronical Characteristics

Item	Symbol	Condition	Standard			Unit	
			Min	Typ	Max		
Input voltage	VDD	+5.0V	4.5	5.0	5.5	V	
		+3.3V	2.7	3.3	4.5		
Supply current	I _{DD}	VDD=5V	----	0.6	0.8	mA	
Recommended LCD driving voltage for normal temp version module	VDD-V0 (VDD=5V)	-20 °C	4.9	5.2	5.5	V	
		0 °C	4.5	4.8	5.1		
		25 °C	4.1	4.5	4.8		
		50 °C	3.8	4.1	4.4		
LED forward voltage	V _F	25 °C	----	3.0	3.3	V	
LED forward current	I _F	25 °C	Array	----	120	----	mA
			Edge	----	30	40	
EL power supply	I _{EL}	V _{EL} =110V AC 400Hz	----	----	5.0	mA	