

WH16020 Character 16x2

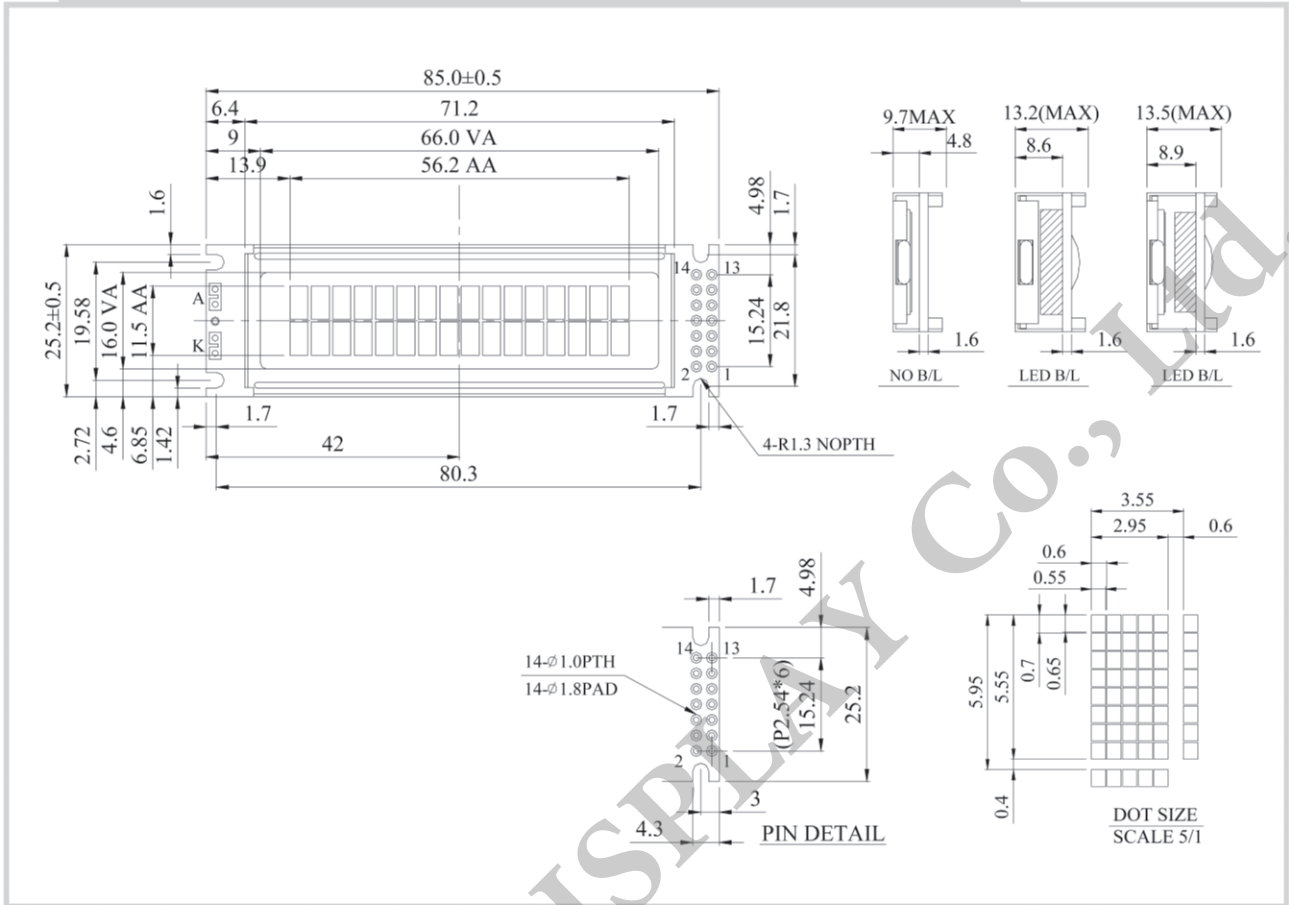

Feature

- 1. 1.5x8 dots includes cursor
- 2. Built-in controller (ST7066 or Equivalent)
- 3. 3.5V power supply only
- 4. N.V, optional for 3V power supply
- 5. 1/16 duty cycle
- 6. Interface : 6800, option SPI/I2C (RW1063 IC)

Pin No.	Symbol	Description
1	DB7	Data bus line
2	DB6	Data bus line
3	DB5	Data bus line
4	DB4	Data bus line
5	DB3	Data bus line
6	DB2	Data bus line
7	DB1	Data bus line
8	DB0	Data bus line
9	E	Enable signal
10	R/W	Read/Write select signal
11	RS	Data/ Instruction select signal
12	V _O	Contrast Adjustment
13	V _{SS}	Ground
14	V _{DD}	Power supply for logic

Mechanical Data

Item	Standard Value	Unit
Module Dimension	85.0 x 25.2	mm
Viewing Area	66.0 x 16.0	mm
Mounting Hole	80.3 x 19.58	mm
Character Size	2.95 x 5.55	mm

Electrical Characteristics

Item	Symbol	Standard Value	Unit
		typ.	
Input Voltage	VDD	5.0	V
Recommended LCD Driving Voltage for Normal Temp. Version module @25°C	VDD-VO	3.70	V