

**YES OPTOELECTRONICS CO.,LTD**

**SPECIFICATIONS**

**Product NO: YMS152152-0150BABMFGN-R**

**DATE: NOV.06.2020**

Prepared by	Approved by
<b>王惠颖</b>	<b>牛红丽</b>



CUSTOMER'S APPROVAL

APPROVED BY: \_\_\_\_\_ DATE: \_\_\_\_\_

**YES OPTOELECTRONICS CO.,LTD**

DD: No.288Yueling Road Anshan,Liaoning,CHINA

TEL: 86-412-5211859 FAX: 86-412-5211729 P.C.:114045

E-mail : [yes@yes-lcd.com](mailto:yes@yes-lcd.com), [yeslcd@globalsources.com](mailto:yeslcd@globalsources.com)

Web: <http://www.yes-lcd.com>

DATE NOV.06.2020	<b>Version</b>	<b>1.0</b>	TECHNICAL SPECIFICATION
LCM	<b>YES</b>	YMS152152-0150BABMFGN-R	Page 1 of 37

## REVISION HISTORY

Rev	Date	Item	Page	Remark
1.0	NOV.06.2020	New Creation	ALL	

DATE NOV.06.2020	<b>Version</b>	<b>1.0</b>	TECHNICAL SPECIFICATION
LCM	<b>YES</b>	YMS152152-0150BABMFGN-R	Page 2 of 37

## LIST

1. Over View-----	(4)
2. Features-----	(4)
3. Mechanical Specifications-----	(4)
4. Mechanical Drawing of EPD module-----	(5)
5. Input /Output Pin Assignment-----	(6-7)
6. Electrical Characteristics-----	(7)
6.1 Absolute Maximum Rating-----	(7)
6.2 Panel DC Characteristics-----	(8)
6.3 Panel AC Characteristics-----	(9)
6.3.1 MCU Interface Selection -----	(9)
6.3.2 MCU Serial Interface(4-wire SPI) -----	(9)
6.3.3 MCU Serial Interface(3-wire SPI) -----	(11)
6.3.4 Interface Timing-----	(12)
7. Command Table -----	(13-25)
8. Optical Specifications -----	(26)
9. Handling, Safety and Environment Requirements -----	(26)
10. Reliability test-----	(27)
11. Block Diagram-----	(28)
12. Typical Application Circuit with SPI Interface -----	(29)
13. Typical Operating Sequence -----	(30)
13.1 Normal Operation Flow -----	(30)
13.2 Normal Operation Reference Program Code-----	(31)
13.3 OTP Operation Flow-----	(32)
13.4 OTP Operation Reference Program Code-----	(33)
14. Part Number Definition-----	(33)
15. Inspection condition-----	(33)
15. 1 Environment-----	(33)
15. 2 Illuminance-----	(33)
15. 3 Inspection method-----	(33)
15. 4 Display area-----	(33)
15. 5 Inspection standard-----	(34)
15. 5.1 Electric inspection standard -----	(34)
15. 5.2 Appearance inspection standard -----	(35-36)
16.Packaging-----	(37)

DATE NOV.06.2020	<b>Version</b>	<b>1.0</b>	TECHNICAL SPECIFICATION
<b>LCM</b>	<b>YES</b>	YMS152152-0150BABMFGN-R	Page 3 of 37

## 1. Over View

YMS152152-0150BABMFGN-R is an Active Matrix Electrophoretic Display (AM EPD), with interface and a reference system design. The display is capable to display images at 1-bit white, black and red full display capabilities. The 1.5 inch active area contains 152×152 pixels. The module is a TFT-array driving electrophoresis display, with integrated circuits including gate driver, source driver, MCU interface, timing controller, oscillator, DC-DC, SRAM, LUT, VCOM. Module can be used in portable electronic devices, such as Electronic Shelf Label (ESL) System.

## 2. Features

- 152x152 pixels display
- High contrast, High reflectance
- Ultra wide viewing angle, Ultra low power consumption
- Pure reflective mode
- Bi-stable display
- Commercial temperature range
- Landscape, portrait modes
- Hard-coat antiglare display surface
- Ultra Low current deep sleep mode
- On chip display RAM
- Waveform stored in On-chip OTP or written by MCU
- Serial peripheral interface available
- On-chip oscillator
- On-chip booster and regulator control for generating VCOM, Gate and source driving voltage .
- I<sup>2</sup>C signal master interface to read external temperature sensor
- Built-in temperature sensor

## 3. Mechanical Specifications

Parameter	Specifications	Unit	Remark
Screen Size	1.5	Inch	
Display Resolution	152(H)×152(V)	Pixel	
Active Area	26.98×26.98	mm	
Pixel Pitch	0.1775×0.1775	mm	
Pixel Configuration	Square		
Outline Dimension	31.8(H)×37.3 2(V) ×1.0 (D)	mm	
Weight	2.18±0.5	g	

DATE NOV.06.2020	<b>Version</b>	<b>1.0</b>	TECHNICAL SPECIFICATION
<b>LCM</b>	<b>YES</b>	YMS152152-0150BABMFGN-R	Page 4 of 37

### 4. Mechanical Drawing of EPD module

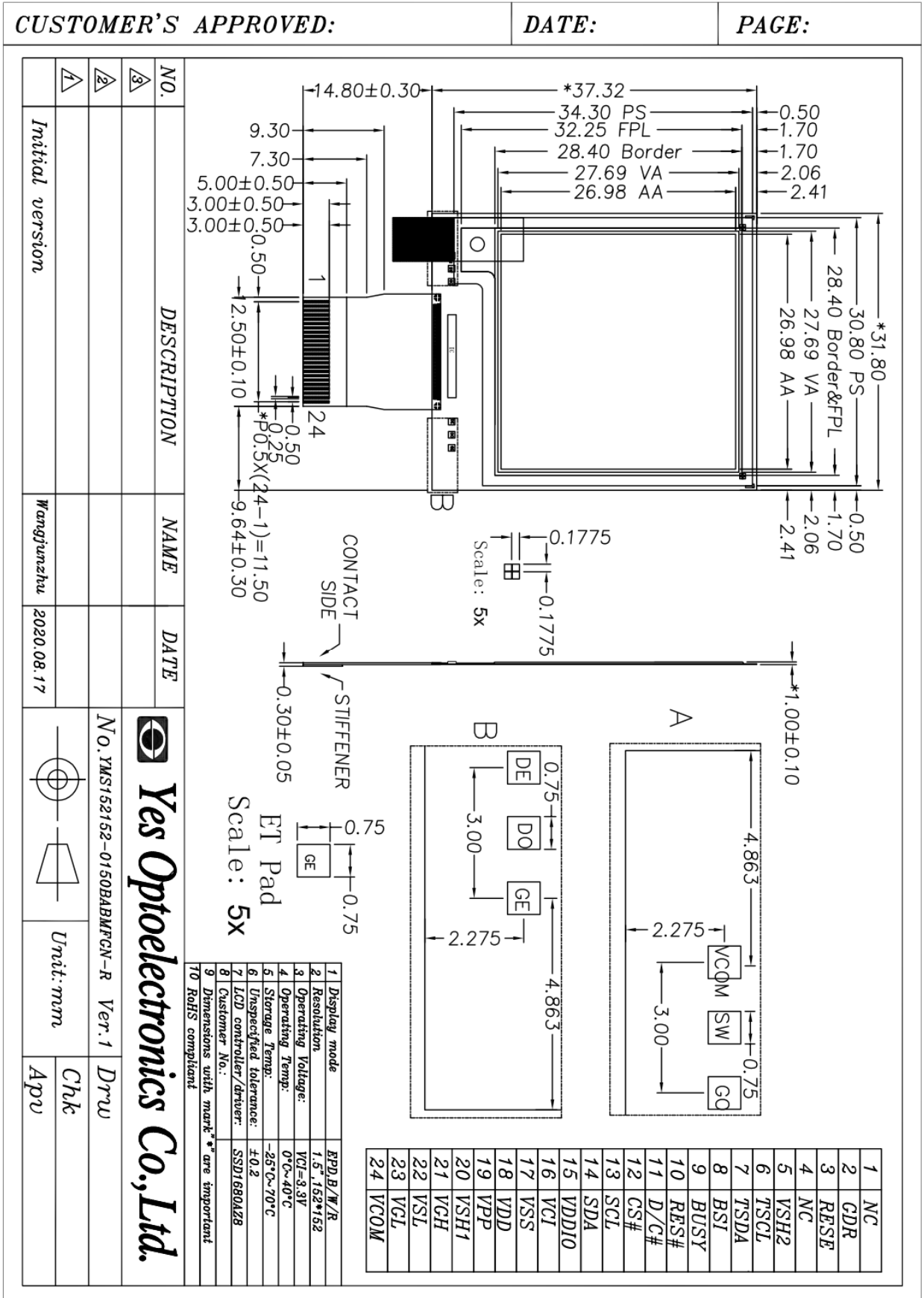

DATE NOV.06.2020	<b>Version</b>	<b>1.0</b>	TECHNICAL SPECIFICATION
<b>LCM</b>	<b>YES</b>	YMS152152-0150BABMFGN-R	Page 5 of 37

## 5. Input /Output Pin Assignment

No.	Name	I/O	Description	Remark
1	NC		Do not connect with other NC pins	Keep Open
2	GDR	O	N-Channel MOSFET Gate Drive Control	
3	RESE	I	Current Sense Input for the Control Loop	
4	NC	NC	Do not connect with other NC pins	Keep Open
5	VSH2	C	Positive Source driving voltage(Red)	
6	TSCL	O	I <sup>2</sup> C Interface to digital temperature sensor Clock pin	
7	TSDA	I/O	I <sup>2</sup> C Interface to digital temperature sensor Data pin	
8	BS1	I	Bus Interface selection pin	Note 5-5
9	BUSY	O	Busy state output pin	Note 5-4
10	RES#	I	Reset signal input. Active Low.	Note 5-3
11	D/C#	I	Data /Command control pin	Note 5-2
12	CS#	I	Chip select input pin	Note 5-1
13	SCL	I	Serial Clock pin (SPI)	
14	SDA	I/O	Serial Data pin (SPI)	
15	VDDIO	P	Power Supply for interface logic pins It should be connected with VCI	
16	VCI	P	Power Supply for the chip	
17	VSS	P	Ground	
18	VDD	C	Core logic power pin VDD can be regulated internally from VCI. A capacitor should be connected between VDD and VSS	
19	VPP	P	FOR TEST	
20	VSH1	C	Positive Source driving voltage	
21	VGH	C	Power Supply pin for Positive Gate driving voltage and VSH1	
22	VSL	C	Negative Source driving voltage	
23	VGL	C	Power Supply pin for Negative Gate driving voltage VCOM and VSL	
24	VCOM	C	VCOM driving voltage	

DATE NOV.06.2020	Version	1.0	TECHNICAL SPECIFICATION
LCM	YES	YMS152152-0150BABMFGN-R	Page 6 of 37

I = Input Pin, O =Output Pin, I/O = Bi-directional Pin (Input/output), P = Power Pin, C =Capacitor Pin

Note 5-1: This pin (CS#) is the chip select input connecting to the MCU. The chip is enabled for MCU communication only when CS# is pulled LOW.

Note 5-2: This pin is (D/C#) Data/Command control pin connecting to the MCU in 4-wire SPI mode. When the pin is pulled HIGH, the data at SDA will be interpreted as data. When the pin is pulled LOW, the data at SDA will be interpreted as command.

Note 5-3: This pin (RES#) is reset signal input. The Reset is active low.

Note 5-4: This pin is Busy state output pin. When Busy is High, the operation of chip should not be interrupted, command should not be sent. The chip would put Busy pin High when  
 –Outputting display waveform  
 –Communicating with digital temperature sensor

Note 5-5: Bus interface selection pin

BS1 State	MCU Interface
L	4-lines serial peripheral interface(SPI) - 8 bits SPI
H	3- lines serial peripheral interface(SPI) - 9 bits SPI

## 6. Electrical Characteristics

### 6.1 Absolute Maximum Rating

Parameter	Symbol	Rating	Unit
Logic supply voltage	VCI	-0.5 to +4.0	V
Logic Input voltage	VIN	-0.5 to VCI +0.5	V
Logic Output voltage	VOUT	-0.5 to VCI +0.5	V
Operating Temp range	TOPR	0 to +40	°C
Storage Temp range	TSTG	-25 to+70	°C
Optimal Storage Temp	TSTGo	23±2	°C
Optimal Storage Humidity	HSTGo	55±10	%RH

Note: Maximum ratings are those values beyond which damages to the device may occur. Functional operation should be restricted to the limits in the Panel DC Characteristics tables.

DATE NOV.06.2020	<b>Version</b>	<b>1.0</b>	TECHNICAL SPECIFICATION
<b>LCM</b>	<b>YES</b>	YMS152152-0150BABMFGN-R	Page 7 of 37

## 6.2 Panel DC Characteristics

The following specifications apply for: VSS=0V, VCI=3.3V, TOPR =23°C

Parameter	Symbol	Conditions	Applicable pin	Min.	Typ.	Max	Units
Single ground	V <sub>SS</sub>	-		-	0	-	V
Logic supply voltage	V <sub>CI</sub>	-	VCI	2.2	3.3	3.7	V
Core logic voltage	V <sub>DD</sub>		VDD	1.7	1.8	1.9	V
High level input voltage	V <sub>IH</sub>	-	-	0.8 V <sub>CI</sub>	-	-	V
Low level input voltage	V <sub>IL</sub>	-	-	-	-	0.2 V <sub>CI</sub>	V
High level output voltage	V <sub>OH</sub>	IOH = -100uA	-	0.9 VCI	-	-	V
Low level output voltage	V <sub>OL</sub>	IOL = 100uA	-	-	-	0.1 VCI	V
Typical power	P <sub>TYP</sub>	V <sub>CI</sub> =3.3V	-	-	13.9	-	mW
Deep sleep mode	P <sub>STPY</sub>	V <sub>CI</sub> =3.3V	-	-	0.003	-	mW
Typical operating current	Iopr_VCI	V <sub>CI</sub> =3.3V	-	-	4.2	-	mA
Image update time	-	25 °C	-	-	16	-	sec
Sleep mode current	Islp_VCI	DC/DC off No clock No input load Ram data retain	-	-	20	-	uA
Deep sleep mode current	Idslp_VCI	DC/DC off No clock No input load Ram data not retain	-	-	1	-	uA

Notes: 1. The typical power is measured with following transition from horizontal 2 scale pattern to vertical 2 scale pattern.

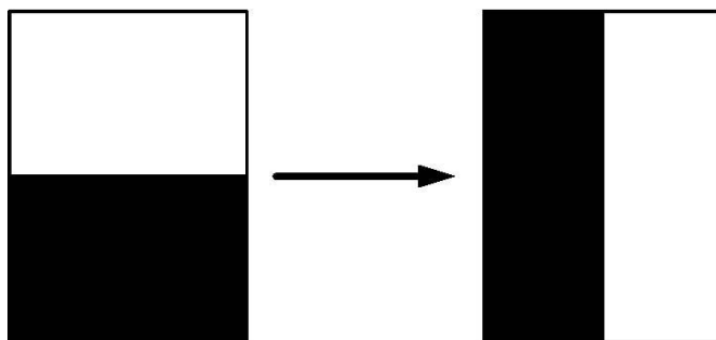

- The deep sleep power is the consumed power when the panel controller is in deep sleep mode.
- The listed electrical/optical characteristics are only guaranteed under the controller & waveform provided by YES

DATE NOV.06.2020	Version	1.0	TECHNICAL SPECIFICATION
LCM	YES	YMS152152-0150BABMFGN-R	Page 8 of 37



## 6.3 Panel AC Characteristics

### 6.3.1 MCU Interface Selection

The pin assignment at different interface mode is summarized in Table 6-4-1. Different MCU mode can be set by hardware selection on BS1 pins. The display panel only supports 4-wire SPI or 3-wire SPI interface mode.

Pin Name	Data/Command Interface		Control Signal		
	Bus interface	SDA	SCL	CS#	D/C#
BS1=L 4-wire SPI	SDA	SCL	CS#	D/C#	RES#
BS1=H 3-wire SPI	SDA	SCL	CS#	L	RES#

### 6.3.2 MCU Serial Interface (4-wire SPI)

The serial interface consists of serial clock SCL, serial data SDA, D/C#, CS#. This interface supports Write mode and Read mode.

Function	CS#	D/C#	SCL
Write command	L	L	↑
Write data	L	H	↑

Note: ↑ stands for rising edge of signal

In the write mode SDA is shifted into an 8-bit shift register on every rising edge of SCL in the order of D7, D6, ... D0. The level of D/C# should be kept over the whole byte. The data byte in the shift register is written to the Graphic Display Data RAM /Data Byte register or command Byte register according to D/C# pin.

DATE NOV.06.2020	<b>Version</b>	<b>1.0</b>	TECHNICAL SPECIFICATION
<b>LCM</b>	<b>YES</b>	YMS152152-0150BABMFGN-R	Page 9 of 37

**Figure 6-1: Write procedure in 4-wire SPI mode**

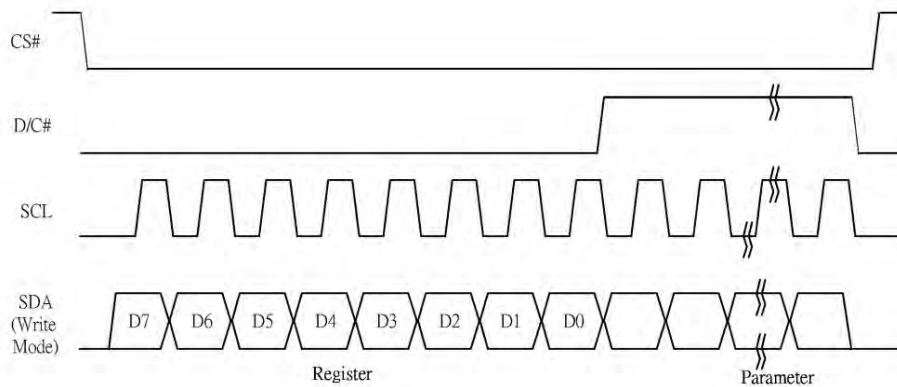

In the Read mode:

1. After driving CS# to low, MCU need to define the register to be read.
2. SDA is shifted into an 8-bit shift register on every rising edge of SCL in the order of D7, D6, ... D0 with D/C# keep low.
3. After SCL change to low for the last bit of register, D/C# need to drive to high.
4. SDA is shifted out an 8-bit data on every falling edge of SCL in the order of D7, D6, ... D0.
5. Depending on register type, more than 1 byte can be read out. After all byte are read, CS# need to drive to high to stop the read operation.

**Figure 6-2: Read procedure in 4-wire SPI mode**

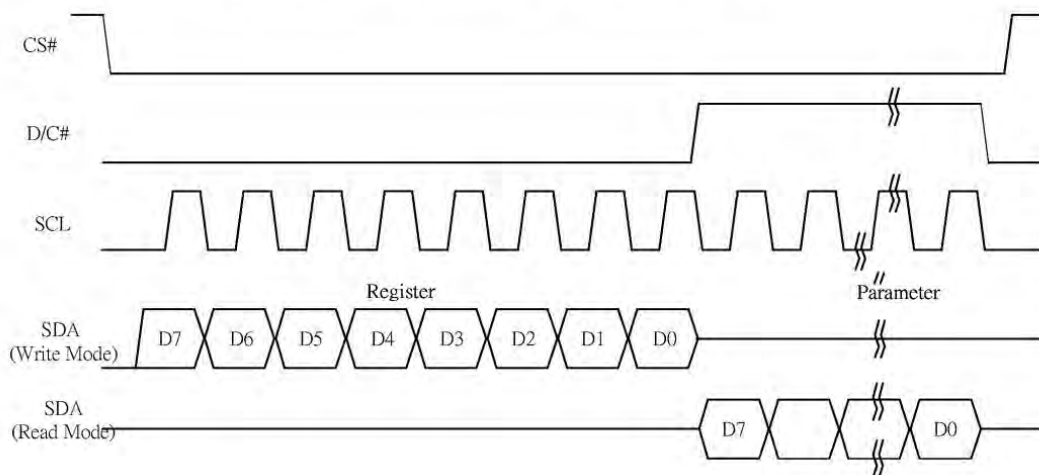

DATE NOV.06.2020	Version	1.0	TECHNICAL SPECIFICATION
LCM	YES	YMS152152-0150BABMFGN-R	Page 10 of 37

### 6.3.3 MCU Serial Interface (3-wire SPI)

The 3-wire serial interface consists of serial clock SCL, serial data SDA and CS#. This interface also supports Write mode and Read mode.

The operation is similar to 4-wire serial interface while D/C# pin is not used. There are altogether 9-bits will be shifted into the shift register on every ninth clock in sequence: D/C# bit, D7 to D0 bit. The D/C# bit (first bit of the sequential data) will determine the following data byte in the shift register is written to the Display Data RAM (D/C# bit = 1) or the command register (D/C# bit = 0).

Function	CS#	D/C#	SCL
Write command	L	Tie	↑
Write data	L	Tie	↑

Note: ↑ stands for rising edge of signal

**Figure 6-3: Write procedure in 3-wire SPI mode**

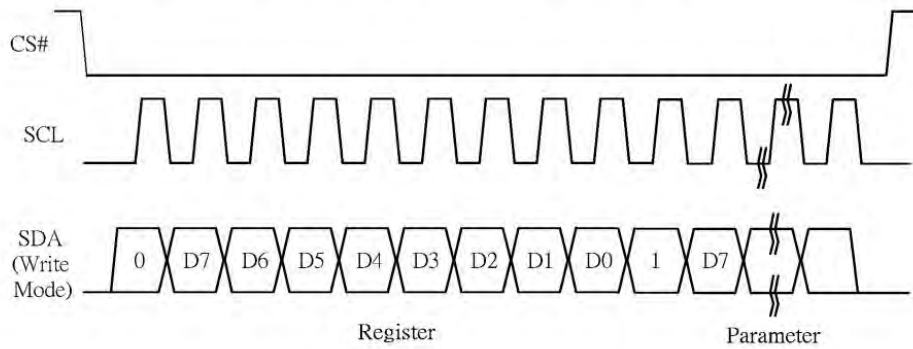

In the Read mode:

1. After driving CS# to low, MCU need to define the register to be read.
2. D/C=0 is shifted thru SDA with one rising edge of SCL
3. SDA is shifted into an 8-bit shift register on every rising edge of SCL in the order of D7, D6, ... D0.
4. D/C=1 is shifted thru SDA with one rising edge of SCL
5. SDA is shifted out an 8-bit data on every falling edge of SCL in the order of D7, D6, ... D0.
6. Depending on register type, more than 1 byte can be read out. After all byte are read, CS# need to drive to high to stop the read operation.

**Figure 6-4: Read procedure in 3-wire SPI mode**

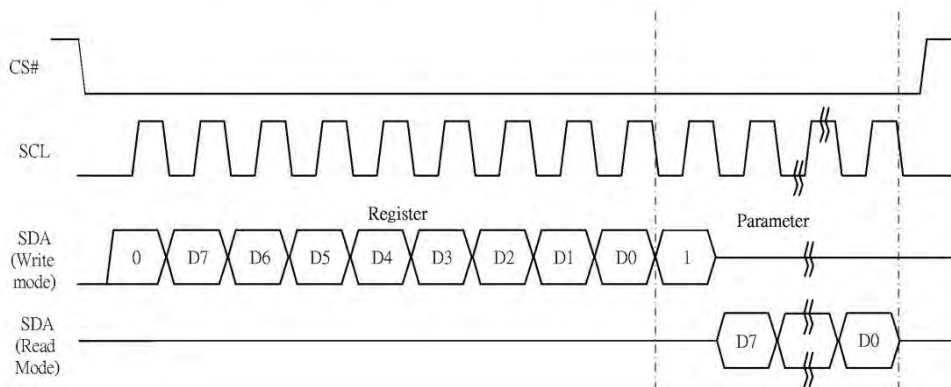

DATE NOV.06.2020	Version	1.0	TECHNICAL SPECIFICATION
LCM	YES	YMS152152-0150BABMFGN-R	Page 11 of 37

### 6.3.4 Interface Timing

The following specifications apply for: VSS=0V, VCI=3.0V, TOPR =25°C.

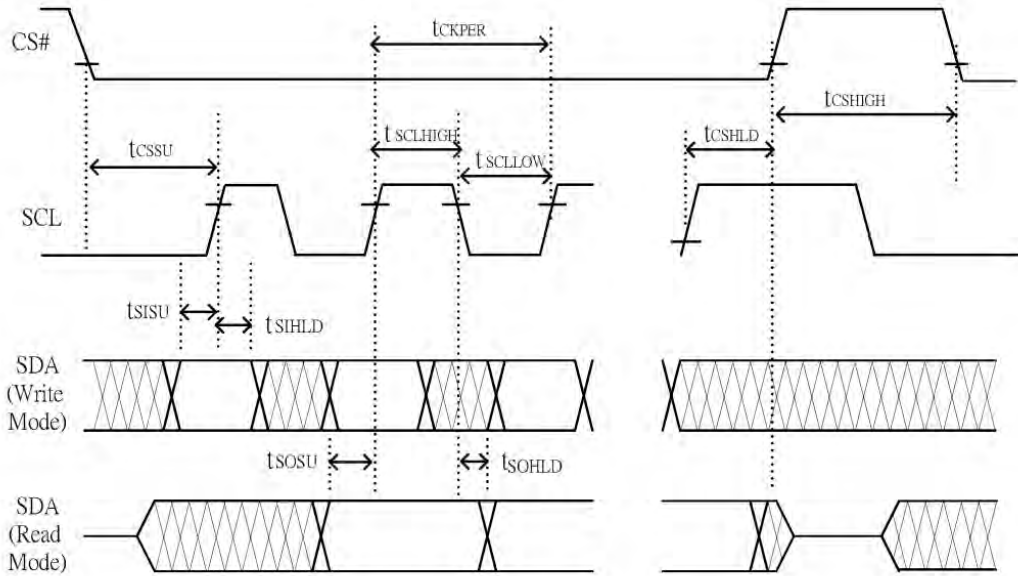

**Changed Diagram**

#### Serial Interface Timing Characteristics

(VCI - VSS = 2.2V to 3.7V, TOPR = 25°C, CL=20pF)

##### Write mode

Symbol	Parameter	Min	Typ	Max	Unit
f <sub>SCL</sub>	SCL frequency (Write Mode)	-	-	20	MHz
t <sub>CSSU</sub>	Time CS# has to be low before the first rising edge of SCLK	60	-	-	ns
t <sub>CSHLD</sub>	Time CS# has to remain low after the last falling edge of SCLK	65	-	-	ns
t <sub>CSHIGH</sub>	Time CS# has to remain high between two transfers	100	-	-	ns
t <sub>SCLHIGH</sub>	Part of the clock period where SCL has to remain high	25	-	-	ns
t <sub>SCLLOW</sub>	Part of the clock period where SCL has to remain low	25	-	-	ns
t <sub>SISU</sub>	Time SI (SDA Write Mode) has to be stable before the next rising edge of SCL	10	-	-	ns
t <sub>SIHLD</sub>	Time SI (SDA Write Mode) has to remain stable after the rising edge of SCL	40	-	-	ns

##### Read mode

Symbol	Parameter	Min	Typ	Max	Unit
f <sub>SCL</sub>	SCL frequency (Read Mode)	-	-	2.5	MHz
t <sub>CSSU</sub>	Time CS# has to be low before the first rising edge of SCLK	100	-	-	ns
t <sub>CSHLD</sub>	Time CS# has to remain low after the last falling edge of SCLK	50	-	-	ns
t <sub>CSHIGH</sub>	Time CS# has to remain high between two transfers	250	-	-	ns
t <sub>SCLHIGH</sub>	Part of the clock period where SCL has to remain high	180	-	-	ns
t <sub>SCLLOW</sub>	Part of the clock period where SCL has to remain low	180	-	-	ns
t <sub>SOSU</sub>	Time SO (SDA Read Mode) will be stable before the next rising edge of SCL	-	50	-	ns
t <sub>SOHLD</sub>	Time SO (SDA Read Mode) will remain stable after the falling edge of SCL	-	0	-	ns

DATE NOV.06.2020	<b>Version</b>	<b>1.0</b>	TECHNICAL SPECIFICATION
<b>LCM</b>	<b>YES</b>	YMS152152-0150BABMFGN-R	Page 12 of 37

## 7. Command Table

Command Table											Command	Description																																																							
R/W#	D/C#	Hex	D7	D6	D5	D4	D3	D2	D1	D0																																																									
0	0	01	0	0	0	0	0	0	0	1	Driver Output control	Gate setting A[8:0]= 127h [POR], 296 MUX MUX Gate lines setting as (A[8:0] + 1).  B [2:0] = 000 [POR]. Gate scanning sequence and direction  B[2]: GD Selects the 1st output Gate GD=0 [POR], G0 is the 1st gate output channel, gate output sequence is G0,G1, G2, G3, ... GD=1, G1 is the 1st gate output channel, gate output sequence is G1, G0, G3, G2, ...  B[1]: SM Change scanning order of gate driver. SM=0 [POR], G0, G1, G2, G3...295 (left and right gate interlaced) SM=1, G0, G2, G4 ...G294, G1, G3, ...G295  B[0]: TB TB = 0 [POR], scan from G0 to G295 TB = 1, scan from G295 to G0.																																																							
0	1		A <sub>7</sub>	A <sub>6</sub>	A <sub>5</sub>	A <sub>4</sub>	A <sub>3</sub>	A <sub>2</sub>	A <sub>1</sub>	A <sub>0</sub>																																																									
0	1		0	0	0	0	0	0	0	A <sub>8</sub>																																																									
0	1		0	0	0	0	0	B <sub>2</sub>	B <sub>1</sub>	B <sub>0</sub>																																																									
0	0	03	0	0	0	0	0	0	1	1	Gate Driving voltage Control	Set Gate driving voltage A[4:0] = 00h [POR] VGH setting from 10V to 20V																																																							
0	1		0	0	0	A <sub>4</sub>	A <sub>3</sub>	A <sub>2</sub>	A <sub>1</sub>	A <sub>0</sub>																																																									
											<table border="1"> <thead> <tr> <th>A[4:0]</th> <th>VGH</th> <th>A[4:0]</th> <th>VGH</th> </tr> </thead> <tbody> <tr> <td>00h</td> <td>20</td> <td>0Dh</td> <td>15</td> </tr> <tr> <td>03h</td> <td>10</td> <td>0Eh</td> <td>15.5</td> </tr> <tr> <td>04h</td> <td>10.5</td> <td>0Fh</td> <td>16</td> </tr> <tr> <td>05h</td> <td>11</td> <td>10h</td> <td>16.5</td> </tr> <tr> <td>06h</td> <td>11.5</td> <td>11h</td> <td>17</td> </tr> <tr> <td>07h</td> <td>12</td> <td>12h</td> <td>17.5</td> </tr> <tr> <td>08h</td> <td>12.5</td> <td>13h</td> <td>18</td> </tr> <tr> <td>07h</td> <td>12</td> <td>14h</td> <td>18.5</td> </tr> <tr> <td>08h</td> <td>12.5</td> <td>15h</td> <td>19</td> </tr> <tr> <td>09h</td> <td>13</td> <td>16h</td> <td>19.5</td> </tr> <tr> <td>0Ah</td> <td>13.5</td> <td>17h</td> <td>20</td> </tr> <tr> <td>0Bh</td> <td>14</td> <td>Other</td> <td>NA</td> </tr> <tr> <td>0Ch</td> <td>14.5</td> <td></td> <td></td> </tr> </tbody> </table>	A[4:0]	VGH	A[4:0]	VGH	00h	20	0Dh	15	03h	10	0Eh	15.5	04h	10.5	0Fh	16	05h	11	10h	16.5	06h	11.5	11h	17	07h	12	12h	17.5	08h	12.5	13h	18	07h	12	14h	18.5	08h	12.5	15h	19	09h	13	16h	19.5	0Ah	13.5	17h	20	0Bh	14	Other	NA	0Ch	14.5		
A[4:0]	VGH	A[4:0]	VGH																																																																
00h	20	0Dh	15																																																																
03h	10	0Eh	15.5																																																																
04h	10.5	0Fh	16																																																																
05h	11	10h	16.5																																																																
06h	11.5	11h	17																																																																
07h	12	12h	17.5																																																																
08h	12.5	13h	18																																																																
07h	12	14h	18.5																																																																
08h	12.5	15h	19																																																																
09h	13	16h	19.5																																																																
0Ah	13.5	17h	20																																																																
0Bh	14	Other	NA																																																																
0Ch	14.5																																																																		

DATE NOV.06.2020	Version	1.0	TECHNICAL SPECIFICATION
LCM	YES	YMS152152-0150BABMFGN-R	Page 13 of 37



Command Table																																																																																																																																																																																																																																																																																																																	
R/W#	D/C#	Hex	D7	D6	D5	D4	D3	D2	D1	D0	Command	Description																																																																																																																																																																																																																																																																																																					
0	0	04	0	0	0	0	0	1	0	0	Source Driving voltage Control	Set Source driving voltage A[7:0] = 41h [POR], VSH1 at 15V B [7:0] = A8h [POR], VSH2 at 5V. C[7:0] = 32h [POR], VSL at -15V Remark: VSH1>=VSH2																																																																																																																																																																																																																																																																																																					
0	1		A7	A6	A5	A4	A3	A2	A1	A0																																																																																																																																																																																																																																																																																																							
0	1		B7	B6	B5	B4	B3	B2	B1	B0																																																																																																																																																																																																																																																																																																							
0	1		C7	C6	C5	C4	C3	C2	C1	C0																																																																																																																																																																																																																																																																																																							
A[7]/B[7] = 1, VSH1/VSH2 voltage setting from 2.4V to 8.8V				A[7]/B[7] = 0, VSH1/VSH2 voltage setting from 9V to 17V				C[7] = 0, VSL setting from -5V to -17V																																																																																																																																																																																																																																																																																																									
<table border="1"> <thead> <tr> <th>A/B[7:0]</th> <th>VSH1/VSH2</th> <th>A/B[7:0]</th> <th>VSH1/VSH2</th> </tr> </thead> <tbody> <tr><td>8Eh</td><td>2.4</td><td>AFh</td><td>5.7</td></tr> <tr><td>8Fh</td><td>2.5</td><td>B0h</td><td>5.8</td></tr> <tr><td>90h</td><td>2.6</td><td>B1h</td><td>5.9</td></tr> <tr><td>91h</td><td>2.7</td><td>B2h</td><td>6</td></tr> <tr><td>92h</td><td>2.8</td><td>B3h</td><td>6.1</td></tr> <tr><td>93h</td><td>2.9</td><td>B4h</td><td>6.2</td></tr> <tr><td>94h</td><td>3</td><td>B5h</td><td>6.3</td></tr> <tr><td>95h</td><td>3.1</td><td>B6h</td><td>6.4</td></tr> <tr><td>96h</td><td>3.2</td><td>B7h</td><td>6.5</td></tr> <tr><td>97h</td><td>3.3</td><td>B8h</td><td>6.6</td></tr> <tr><td>98h</td><td>3.4</td><td>B9h</td><td>6.7</td></tr> <tr><td>99h</td><td>3.5</td><td>BAh</td><td>6.8</td></tr> <tr><td>9Ah</td><td>3.6</td><td>BBh</td><td>6.9</td></tr> <tr><td>9Bh</td><td>3.7</td><td>BC h</td><td>7</td></tr> <tr><td>9Ch</td><td>3.8</td><td>BDh</td><td>7.1</td></tr> <tr><td>9Dh</td><td>3.9</td><td>BEh</td><td>7.2</td></tr> <tr><td>9Eh</td><td>4</td><td>BFh</td><td>7.3</td></tr> <tr><td>9Fh</td><td>4.1</td><td>C0h</td><td>7.4</td></tr> <tr><td>A0h</td><td>4.2</td><td>C1h</td><td>7.5</td></tr> <tr><td>A1h</td><td>4.3</td><td>C2h</td><td>7.6</td></tr> <tr><td>A2h</td><td>4.4</td><td>C3h</td><td>7.7</td></tr> <tr><td>A3h</td><td>4.5</td><td>C4h</td><td>7.8</td></tr> <tr><td>A4h</td><td>4.6</td><td>C5h</td><td>7.9</td></tr> <tr><td>A5h</td><td>4.7</td><td>C6h</td><td>8</td></tr> <tr><td>A6h</td><td>4.8</td><td>C7h</td><td>8.1</td></tr> <tr><td>A7h</td><td>4.9</td><td>C8h</td><td>8.2</td></tr> <tr><td>A8h</td><td>5</td><td>C9h</td><td>8.3</td></tr> <tr><td>A9h</td><td>5.1</td><td>CAh</td><td>8.4</td></tr> <tr><td>AAh</td><td>5.2</td><td>CBh</td><td>8.5</td></tr> <tr><td>ABh</td><td>5.3</td><td>CCh</td><td>8.6</td></tr> <tr><td>ACH</td><td>5.4</td><td>CDh</td><td>8.7</td></tr> <tr><td>ADh</td><td>5.5</td><td>CEh</td><td>8.8</td></tr> <tr><td>AEh</td><td>5.6</td><td>Other</td><td>NA</td></tr> </tbody> </table>				A/B[7:0]	VSH1/VSH2	A/B[7:0]	VSH1/VSH2	8Eh	2.4	AFh	5.7	8Fh	2.5	B0h	5.8	90h	2.6	B1h	5.9	91h	2.7	B2h	6	92h	2.8	B3h	6.1	93h	2.9	B4h	6.2	94h	3	B5h	6.3	95h	3.1	B6h	6.4	96h	3.2	B7h	6.5	97h	3.3	B8h	6.6	98h	3.4	B9h	6.7	99h	3.5	BAh	6.8	9Ah	3.6	BBh	6.9	9Bh	3.7	BC h	7	9Ch	3.8	BDh	7.1	9Dh	3.9	BEh	7.2	9Eh	4	BFh	7.3	9Fh	4.1	C0h	7.4	A0h	4.2	C1h	7.5	A1h	4.3	C2h	7.6	A2h	4.4	C3h	7.7	A3h	4.5	C4h	7.8	A4h	4.6	C5h	7.9	A5h	4.7	C6h	8	A6h	4.8	C7h	8.1	A7h	4.9	C8h	8.2	A8h	5	C9h	8.3	A9h	5.1	CAh	8.4	AAh	5.2	CBh	8.5	ABh	5.3	CCh	8.6	ACH	5.4	CDh	8.7	ADh	5.5	CEh	8.8	AEh	5.6	Other	NA	<table border="1"> <thead> <tr> <th>A/B[7:0]</th> <th>VSH1/VSH2</th> <th>A/B[7:0]</th> <th>VSH1/VSH2</th> </tr> </thead> <tbody> <tr><td>23h</td><td>9</td><td>3Ch</td><td>14</td></tr> <tr><td>24h</td><td>9.2</td><td>3Dh</td><td>14.2</td></tr> <tr><td>25h</td><td>9.4</td><td>3Eh</td><td>14.4</td></tr> <tr><td>26h</td><td>9.6</td><td>3Fh</td><td>14.6</td></tr> <tr><td>27h</td><td>9.8</td><td>40h</td><td>14.8</td></tr> <tr><td>28h</td><td>10</td><td>41h</td><td>15</td></tr> <tr><td>29h</td><td>10.2</td><td>42h</td><td>15.2</td></tr> <tr><td>2Ah</td><td>10.4</td><td>43h</td><td>15.4</td></tr> <tr><td>2Bh</td><td>10.6</td><td>44h</td><td>15.6</td></tr> <tr><td>2Ch</td><td>10.8</td><td>45h</td><td>15.8</td></tr> <tr><td>2Dh</td><td>11</td><td>46h</td><td>16</td></tr> <tr><td>2Eh</td><td>11.2</td><td>47h</td><td>16.2</td></tr> <tr><td>2Fh</td><td>11.4</td><td>48h</td><td>16.4</td></tr> <tr><td>30h</td><td>11.6</td><td>49h</td><td>16.6</td></tr> <tr><td>31h</td><td>11.8</td><td>4Ah</td><td>16.8</td></tr> <tr><td>32h</td><td>12</td><td>4Bh</td><td>17</td></tr> <tr><td>33h</td><td>12.2</td><td>Other</td><td>NA</td></tr> <tr><td>34h</td><td>12.4</td><td></td><td></td></tr> <tr><td>35h</td><td>12.6</td><td></td><td></td></tr> <tr><td>36h</td><td>12.8</td><td></td><td></td></tr> <tr><td>37h</td><td>13</td><td></td><td></td></tr> <tr><td>38h</td><td>13.2</td><td></td><td></td></tr> <tr><td>39h</td><td>13.4</td><td></td><td></td></tr> <tr><td>3Ah</td><td>13.6</td><td></td><td></td></tr> <tr><td>3Bh</td><td>13.8</td><td></td><td></td></tr> </tbody> </table>				A/B[7:0]	VSH1/VSH2	A/B[7:0]	VSH1/VSH2	23h	9	3Ch	14	24h	9.2	3Dh	14.2	25h	9.4	3Eh	14.4	26h	9.6	3Fh	14.6	27h	9.8	40h	14.8	28h	10	41h	15	29h	10.2	42h	15.2	2Ah	10.4	43h	15.4	2Bh	10.6	44h	15.6	2Ch	10.8	45h	15.8	2Dh	11	46h	16	2Eh	11.2	47h	16.2	2Fh	11.4	48h	16.4	30h	11.6	49h	16.6	31h	11.8	4Ah	16.8	32h	12	4Bh	17	33h	12.2	Other	NA	34h	12.4			35h	12.6			36h	12.8			37h	13			38h	13.2			39h	13.4			3Ah	13.6			3Bh	13.8			<table border="1"> <thead> <tr> <th>C[7:0]</th> <th>VSL</th> </tr> </thead> <tbody> <tr><td>0Ah</td><td>-5</td></tr> <tr><td>0Ch</td><td>-5.5</td></tr> <tr><td>0Eh</td><td>-6</td></tr> <tr><td>10h</td><td>-6.5</td></tr> <tr><td>12h</td><td>-7</td></tr> <tr><td>14h</td><td>-7.5</td></tr> <tr><td>16h</td><td>-8</td></tr> <tr><td>18h</td><td>-8.5</td></tr> <tr><td>1Ah</td><td>-9</td></tr> <tr><td>1Ch</td><td>-9.5</td></tr> <tr><td>1Eh</td><td>-10</td></tr> <tr><td>20h</td><td>-10.5</td></tr> <tr><td>22h</td><td>-11</td></tr> <tr><td>24h</td><td>-11.5</td></tr> <tr><td>26h</td><td>-12</td></tr> <tr><td>28h</td><td>-12.5</td></tr> <tr><td>2Ah</td><td>-13</td></tr> <tr><td>2Ch</td><td>-13.5</td></tr> <tr><td>2Eh</td><td>-14</td></tr> <tr><td>30h</td><td>-14.5</td></tr> <tr><td>32h</td><td>-15</td></tr> <tr><td>34h</td><td>-15.5</td></tr> <tr><td>36h</td><td>-16</td></tr> <tr><td>38h</td><td>-16.5</td></tr> <tr><td>3Ah</td><td>-17</td></tr> <tr><td>Other</td><td>NA</td></tr> </tbody> </table>				C[7:0]	VSL	0Ah	-5	0Ch	-5.5	0Eh	-6	10h	-6.5	12h	-7	14h	-7.5	16h	-8	18h	-8.5	1Ah	-9	1Ch	-9.5	1Eh	-10	20h	-10.5	22h	-11	24h	-11.5	26h	-12	28h	-12.5	2Ah	-13	2Ch	-13.5	2Eh	-14	30h	-14.5	32h	-15	34h	-15.5	36h	-16	38h	-16.5	3Ah	-17	Other	NA
A/B[7:0]	VSH1/VSH2	A/B[7:0]	VSH1/VSH2																																																																																																																																																																																																																																																																																																														
8Eh	2.4	AFh	5.7																																																																																																																																																																																																																																																																																																														
8Fh	2.5	B0h	5.8																																																																																																																																																																																																																																																																																																														
90h	2.6	B1h	5.9																																																																																																																																																																																																																																																																																																														
91h	2.7	B2h	6																																																																																																																																																																																																																																																																																																														
92h	2.8	B3h	6.1																																																																																																																																																																																																																																																																																																														
93h	2.9	B4h	6.2																																																																																																																																																																																																																																																																																																														
94h	3	B5h	6.3																																																																																																																																																																																																																																																																																																														
95h	3.1	B6h	6.4																																																																																																																																																																																																																																																																																																														
96h	3.2	B7h	6.5																																																																																																																																																																																																																																																																																																														
97h	3.3	B8h	6.6																																																																																																																																																																																																																																																																																																														
98h	3.4	B9h	6.7																																																																																																																																																																																																																																																																																																														
99h	3.5	BAh	6.8																																																																																																																																																																																																																																																																																																														
9Ah	3.6	BBh	6.9																																																																																																																																																																																																																																																																																																														
9Bh	3.7	BC h	7																																																																																																																																																																																																																																																																																																														
9Ch	3.8	BDh	7.1																																																																																																																																																																																																																																																																																																														
9Dh	3.9	BEh	7.2																																																																																																																																																																																																																																																																																																														
9Eh	4	BFh	7.3																																																																																																																																																																																																																																																																																																														
9Fh	4.1	C0h	7.4																																																																																																																																																																																																																																																																																																														
A0h	4.2	C1h	7.5																																																																																																																																																																																																																																																																																																														
A1h	4.3	C2h	7.6																																																																																																																																																																																																																																																																																																														
A2h	4.4	C3h	7.7																																																																																																																																																																																																																																																																																																														
A3h	4.5	C4h	7.8																																																																																																																																																																																																																																																																																																														
A4h	4.6	C5h	7.9																																																																																																																																																																																																																																																																																																														
A5h	4.7	C6h	8																																																																																																																																																																																																																																																																																																														
A6h	4.8	C7h	8.1																																																																																																																																																																																																																																																																																																														
A7h	4.9	C8h	8.2																																																																																																																																																																																																																																																																																																														
A8h	5	C9h	8.3																																																																																																																																																																																																																																																																																																														
A9h	5.1	CAh	8.4																																																																																																																																																																																																																																																																																																														
AAh	5.2	CBh	8.5																																																																																																																																																																																																																																																																																																														
ABh	5.3	CCh	8.6																																																																																																																																																																																																																																																																																																														
ACH	5.4	CDh	8.7																																																																																																																																																																																																																																																																																																														
ADh	5.5	CEh	8.8																																																																																																																																																																																																																																																																																																														
AEh	5.6	Other	NA																																																																																																																																																																																																																																																																																																														
A/B[7:0]	VSH1/VSH2	A/B[7:0]	VSH1/VSH2																																																																																																																																																																																																																																																																																																														
23h	9	3Ch	14																																																																																																																																																																																																																																																																																																														
24h	9.2	3Dh	14.2																																																																																																																																																																																																																																																																																																														
25h	9.4	3Eh	14.4																																																																																																																																																																																																																																																																																																														
26h	9.6	3Fh	14.6																																																																																																																																																																																																																																																																																																														
27h	9.8	40h	14.8																																																																																																																																																																																																																																																																																																														
28h	10	41h	15																																																																																																																																																																																																																																																																																																														
29h	10.2	42h	15.2																																																																																																																																																																																																																																																																																																														
2Ah	10.4	43h	15.4																																																																																																																																																																																																																																																																																																														
2Bh	10.6	44h	15.6																																																																																																																																																																																																																																																																																																														
2Ch	10.8	45h	15.8																																																																																																																																																																																																																																																																																																														
2Dh	11	46h	16																																																																																																																																																																																																																																																																																																														
2Eh	11.2	47h	16.2																																																																																																																																																																																																																																																																																																														
2Fh	11.4	48h	16.4																																																																																																																																																																																																																																																																																																														
30h	11.6	49h	16.6																																																																																																																																																																																																																																																																																																														
31h	11.8	4Ah	16.8																																																																																																																																																																																																																																																																																																														
32h	12	4Bh	17																																																																																																																																																																																																																																																																																																														
33h	12.2	Other	NA																																																																																																																																																																																																																																																																																																														
34h	12.4																																																																																																																																																																																																																																																																																																																
35h	12.6																																																																																																																																																																																																																																																																																																																
36h	12.8																																																																																																																																																																																																																																																																																																																
37h	13																																																																																																																																																																																																																																																																																																																
38h	13.2																																																																																																																																																																																																																																																																																																																
39h	13.4																																																																																																																																																																																																																																																																																																																
3Ah	13.6																																																																																																																																																																																																																																																																																																																
3Bh	13.8																																																																																																																																																																																																																																																																																																																
C[7:0]	VSL																																																																																																																																																																																																																																																																																																																
0Ah	-5																																																																																																																																																																																																																																																																																																																
0Ch	-5.5																																																																																																																																																																																																																																																																																																																
0Eh	-6																																																																																																																																																																																																																																																																																																																
10h	-6.5																																																																																																																																																																																																																																																																																																																
12h	-7																																																																																																																																																																																																																																																																																																																
14h	-7.5																																																																																																																																																																																																																																																																																																																
16h	-8																																																																																																																																																																																																																																																																																																																
18h	-8.5																																																																																																																																																																																																																																																																																																																
1Ah	-9																																																																																																																																																																																																																																																																																																																
1Ch	-9.5																																																																																																																																																																																																																																																																																																																
1Eh	-10																																																																																																																																																																																																																																																																																																																
20h	-10.5																																																																																																																																																																																																																																																																																																																
22h	-11																																																																																																																																																																																																																																																																																																																
24h	-11.5																																																																																																																																																																																																																																																																																																																
26h	-12																																																																																																																																																																																																																																																																																																																
28h	-12.5																																																																																																																																																																																																																																																																																																																
2Ah	-13																																																																																																																																																																																																																																																																																																																
2Ch	-13.5																																																																																																																																																																																																																																																																																																																
2Eh	-14																																																																																																																																																																																																																																																																																																																
30h	-14.5																																																																																																																																																																																																																																																																																																																
32h	-15																																																																																																																																																																																																																																																																																																																
34h	-15.5																																																																																																																																																																																																																																																																																																																
36h	-16																																																																																																																																																																																																																																																																																																																
38h	-16.5																																																																																																																																																																																																																																																																																																																
3Ah	-17																																																																																																																																																																																																																																																																																																																
Other	NA																																																																																																																																																																																																																																																																																																																
0	0	08	0	0	0	0	1	0	0	0	Initial Code Setting OTP Program	Program Initial Code Setting  The command required CLKEN=1. Refer to Register 0x22 for detail. BUSY pad will output high during operation.																																																																																																																																																																																																																																																																																																					
0	0	09	0	0	0	0	1	0	0	1	Write Register for Initial Code Setting	Write Register for Initial Code Setting Selection A[7:0] ~ D[7:0]: Reserved Details refer to Application Notes of Initial Code Setting																																																																																																																																																																																																																																																																																																					
0	1		A7	A6	A5	A4	A3	A2	A1	A0																																																																																																																																																																																																																																																																																																							
0	1		B7	B6	B5	B4	B3	B2	B1	B0																																																																																																																																																																																																																																																																																																							
0	1		C7	C6	C5	C4	C3	C2	C1	C0																																																																																																																																																																																																																																																																																																							
0	1		D7	D6	D5	D4	D3	D2	D1	D0																																																																																																																																																																																																																																																																																																							
0	0	0A	0	0	0	0	1	0	1	0	Read Register for Initial Code Setting	Read Register for Initial Code Setting																																																																																																																																																																																																																																																																																																					

DATE NOV.06.2020	Version	1.0	TECHNICAL SPECIFICATION
LCM	YES	YMS152152-0150BABMFGN-R	Page 14 of 37

Command Table											Command	Description																																																
R/W#	D/C#	Hex	D7	D6	D5	D4	D3	D2	D1	D0																																																		
0	0	0C	0	0	0	0	1	1	0	0	Booster Soft start Control	Booster Enable with Phase 1, Phase 2 and Phase 3 for soft start current and duration setting.  A[7:0] -> Soft start setting for Phase1 = 8Bh [POR] B[7:0] -> Soft start setting for Phase2 = 9Ch [POR] C[7:0] -> Soft start setting for Phase3 = 96h [POR] D[7:0] -> Duration setting = 0Fh [POR]  Bit Description of each byte: A[6:0] / B[6:0] / C[6:0]:																																																
0	1		1	A <sub>6</sub>	A <sub>5</sub>	A <sub>4</sub>	A <sub>3</sub>	A <sub>2</sub>	A <sub>1</sub>	A <sub>0</sub>																																																		
0	1		1	B <sub>6</sub>	B <sub>5</sub>	B <sub>4</sub>	B <sub>3</sub>	B <sub>2</sub>	B <sub>1</sub>	B <sub>0</sub>																																																		
0	1		1	C <sub>6</sub>	C <sub>5</sub>	C <sub>4</sub>	C <sub>3</sub>	C <sub>2</sub>	C <sub>1</sub>	C <sub>0</sub>																																																		
0	1		0	0	D <sub>5</sub>	D <sub>4</sub>	D <sub>3</sub>	D <sub>2</sub>	D <sub>1</sub>	D <sub>0</sub>																																																		
												<table border="1"> <thead> <tr> <th>Bit[6:4]</th> <th>Driving Strength Selection</th> </tr> </thead> <tbody> <tr><td>000</td><td>1(Weakest)</td></tr> <tr><td>001</td><td>2</td></tr> <tr><td>010</td><td>3</td></tr> <tr><td>011</td><td>4</td></tr> <tr><td>100</td><td>5</td></tr> <tr><td>101</td><td>6</td></tr> <tr><td>110</td><td>7</td></tr> <tr><td>111</td><td>8(Strongest)</td></tr> </tbody> </table> <table border="1"> <thead> <tr> <th>Bit[3:0]</th> <th>Min Off Time Setting of GDR [ Time unit ]</th> </tr> </thead> <tbody> <tr><td>0000</td><td>NA</td></tr> <tr><td>0011</td><td></td></tr> <tr><td>0100</td><td>2.6</td></tr> <tr><td>0101</td><td>3.2</td></tr> <tr><td>0110</td><td>3.9</td></tr> <tr><td>0111</td><td>4.6</td></tr> <tr><td>1000</td><td>5.4</td></tr> <tr><td>1001</td><td>6.3</td></tr> <tr><td>1010</td><td>7.3</td></tr> <tr><td>1011</td><td>8.4</td></tr> <tr><td>1100</td><td>9.8</td></tr> <tr><td>1101</td><td>11.5</td></tr> <tr><td>1110</td><td>13.8</td></tr> <tr><td>1111</td><td>16.5</td></tr> </tbody> </table> D[5:0]: duration setting of phase D[4:4]: duration setting of phase 3 D[3:2]: duration setting of phase 2 D[1:0]: duration setting of phase 1	Bit[6:4]	Driving Strength Selection	000	1(Weakest)	001	2	010	3	011	4	100	5	101	6	110	7	111	8(Strongest)	Bit[3:0]	Min Off Time Setting of GDR [ Time unit ]	0000	NA	0011		0100	2.6	0101	3.2	0110	3.9	0111	4.6	1000	5.4	1001	6.3	1010	7.3	1011	8.4	1100	9.8	1101	11.5	1110	13.8	1111	16.5
Bit[6:4]	Driving Strength Selection																																																											
000	1(Weakest)																																																											
001	2																																																											
010	3																																																											
011	4																																																											
100	5																																																											
101	6																																																											
110	7																																																											
111	8(Strongest)																																																											
Bit[3:0]	Min Off Time Setting of GDR [ Time unit ]																																																											
0000	NA																																																											
0011																																																												
0100	2.6																																																											
0101	3.2																																																											
0110	3.9																																																											
0111	4.6																																																											
1000	5.4																																																											
1001	6.3																																																											
1010	7.3																																																											
1011	8.4																																																											
1100	9.8																																																											
1101	11.5																																																											
1110	13.8																																																											
1111	16.5																																																											
												<table border="1"> <thead> <tr> <th>Bit[1:0]</th> <th>Duration of Phase [Approximation]</th> </tr> </thead> <tbody> <tr><td>00</td><td>10ms</td></tr> <tr><td>01</td><td>20ms</td></tr> <tr><td>10</td><td>30ms</td></tr> <tr><td>11</td><td>40ms</td></tr> </tbody> </table>	Bit[1:0]	Duration of Phase [Approximation]	00	10ms	01	20ms	10	30ms	11	40ms																																						
Bit[1:0]	Duration of Phase [Approximation]																																																											
00	10ms																																																											
01	20ms																																																											
10	30ms																																																											
11	40ms																																																											
0	0	10	0	0	0	1	0	0	0	0	Deep Sleep mode	Deep Sleep mode Control:																																																
0	1		0	0	0	0	0	0	A <sub>1</sub>	A <sub>0</sub>																																																		
												<table border="1"> <thead> <tr> <th>A[1:0]</th> <th>Description</th> </tr> </thead> <tbody> <tr><td>00</td><td>Normal Mode [POR]</td></tr> <tr><td>01</td><td>Enter Deep Sleep Mode 1</td></tr> <tr><td>11</td><td>Enter Deep Sleep Mode 2</td></tr> </tbody> </table> After this command initiated, the chip will enter Deep Sleep Mode, BUSY pad will keep output high. Remark: To Exit Deep Sleep mode, User required to send HWRESET to the driver	A[1:0]	Description	00	Normal Mode [POR]	01	Enter Deep Sleep Mode 1	11	Enter Deep Sleep Mode 2																																								
A[1:0]	Description																																																											
00	Normal Mode [POR]																																																											
01	Enter Deep Sleep Mode 1																																																											
11	Enter Deep Sleep Mode 2																																																											

DATE NOV.06.2020	Version	1.0	TECHNICAL SPECIFICATION
LCM	YES	YMS152152-0150BABMFGN-R	Page 15 of 37

Command Table												
R/W#	D/C#	Hex	D7	D6	D5	D4	D3	D2	D1	D0	Command	Description
0	0	11	0	0	0	1	0	0	0	1	Data Entry mode setting	Define data entry sequence A[2:0] = 011 [POR]  A [1:0] = ID[1:0] Address automatic increment / decrement setting The setting of incrementing or decrementing of the address counter can be made independently in each upper and lower bit of the address. 00 –Y decrement, X decrement, 01 –Y decrement, X increment, 10 –Y increment, X decrement, 11 –Y increment, X increment [POR]  A[2] = AM Set the direction in which the address counter is updated automatically after data are written to the RAM. AM= 0, the address counter is updated in the X direction. [POR] AM = 1, the address counter is updated in the Y direction.
0	1		0	0	0	0	0	A <sub>2</sub>	A <sub>1</sub>	A <sub>0</sub>		
0	0	12	0	0	0	1	0	0	1	0	SW RESET	It resets the commands and parameters to their S/W Reset default values except R10h-Deep Sleep Mode  During operation, BUSY pad will output high.  Note: RAM are unaffected by this command.
0	0	14	0	0	0	1	0	1	0	0	HV Ready Detection	HV ready detection A[7:0] = 00h [POR] The command required CLKEN=1 and ANALOGEN=1. Refer to Register 0x22 for detail. After this command initiated, HV Ready detection starts. BUSY pad will output high during detection. The detection result can be read from the Status Bit Read (Command 0x2F).  A[6:4]=n for cool down duration: 10ms x (n+1) A[2:0]=m for number of Cool Down Loop to detect. The max HV ready duration is 10ms x (n+1) x (m) HV ready detection will be trigger after each cool down time. The detection will be completed when HV is ready. For 1 shot HV ready detection, A[7:0] can be set as 00h.
0	1		0	A <sub>6</sub>	A <sub>5</sub>	A <sub>4</sub>	0	A <sub>2</sub>	A <sub>1</sub>	A <sub>0</sub>		

DATE NOV.06.2020	Version	1.0	TECHNICAL SPECIFICATION
LCM	YES	YMS152152-0150BABMFGN-R	Page 16 of 37



Command Table																										
R/W#	D/C#	Hex	D7	D6	D5	D4	D3	D2	D1	D0	Command	Description														
0	0	15	0	0	0	1	0	1	0	1	VCI Detection	VCI Detection A[2:0] = 100 [POR], Detect level at 2.3V A[2:0] : VCI level Detect <table border="1" style="margin-left: 20px;"> <tr> <th>A[2:0]</th> <th>VCI level</th> </tr> <tr> <td>011</td> <td>2.2V</td> </tr> <tr> <td>100</td> <td>2.3V</td> </tr> <tr> <td>101</td> <td>2.4V</td> </tr> <tr> <td>110</td> <td>2.5V</td> </tr> <tr> <td>111</td> <td>2.6V</td> </tr> <tr> <td>Other</td> <td>NA</td> </tr> </table> <p>The command required CLKEN=1 and ANALOGEN=1 Refer to Register 0x22 for detail.</p> <p>After this command initiated, VCI detection starts. BUSY pad will output high during detection. The detection result can be read from the Status Bit Read (Command 0x2F).</p>	A[2:0]	VCI level	011	2.2V	100	2.3V	101	2.4V	110	2.5V	111	2.6V	Other	NA
A[2:0]	VCI level																									
011	2.2V																									
100	2.3V																									
101	2.4V																									
110	2.5V																									
111	2.6V																									
Other	NA																									
0	1		0	0	0	0	0	A <sub>2</sub>	A <sub>1</sub>	A <sub>0</sub>																
0	0	18	0	0	0	1	1	0	0	0	Temperature Sensor Control	Temperature Sensor Selection A[7:0] = 48h [POR], external temperature sensor A[7:0] = 80h Internal temperature sensor														
0	1		A <sub>7</sub>	A <sub>6</sub>	A <sub>5</sub>	A <sub>4</sub>	A <sub>3</sub>	A <sub>2</sub>	A <sub>1</sub>	A <sub>0</sub>																
0	0	1A	0	0	0	1	1	0	1	0	Temperature Sensor Control (Write to temperature register)	Write to temperature register. A[7:0] = 7Fh [POR]														
0	1		A <sub>7</sub>	A <sub>6</sub>	A <sub>5</sub>	A <sub>4</sub>	A <sub>3</sub>	A <sub>2</sub>	A <sub>1</sub>	A <sub>0</sub>																
0	0	1B	0	0	0	1	1	0	1	1	Temperature Sensor Control (Read from temperature register)	Read from temperature register.														
1	1		A <sub>7</sub>	A <sub>6</sub>	A <sub>5</sub>	A <sub>4</sub>	A <sub>3</sub>	A <sub>2</sub>	A <sub>1</sub>	A <sub>0</sub>																
0	0	1C	0	0	0	1	1	1	0	0	Temperature Sensor Control (Write Command to External temperature sensor)	Write Command to External temperature sensor. A[7:0] = 00h [POR], B[7:0] = 00h [POR], C[7:0] = 00h [POR],  A[7:6] <table border="1" style="margin-left: 20px;"> <tr> <th>A[7:6]</th> <th>Select no of byte to be sent</th> </tr> <tr> <td>00</td> <td>Address + pointer</td> </tr> <tr> <td>01</td> <td>Address + pointer + 1st parameter</td> </tr> <tr> <td>10</td> <td>Address + pointer + 1st parameter + 2nd pointer</td> </tr> <tr> <td>11</td> <td>Address</td> </tr> </table> A[5:0] – Pointer Setting B[7:0] – 1 <sup>st</sup> parameter C[7:0] – 2 <sup>nd</sup> parameter The command required CLKEN=1. Refer to Register 0x22 for detail.	A[7:6]	Select no of byte to be sent	00	Address + pointer	01	Address + pointer + 1st parameter	10	Address + pointer + 1st parameter + 2nd pointer	11	Address				
A[7:6]	Select no of byte to be sent																									
00	Address + pointer																									
01	Address + pointer + 1st parameter																									
10	Address + pointer + 1st parameter + 2nd pointer																									
11	Address																									
0	1		A <sub>7</sub>	A <sub>6</sub>	A <sub>5</sub>	A <sub>4</sub>	A <sub>3</sub>	A <sub>2</sub>	A <sub>1</sub>	A <sub>0</sub>																
0	1		B <sub>7</sub>	B <sub>6</sub>	B <sub>5</sub>	B <sub>4</sub>	B <sub>3</sub>	B <sub>2</sub>	B <sub>1</sub>	B <sub>0</sub>																
0	1		C <sub>7</sub>	C <sub>6</sub>	C <sub>5</sub>	C <sub>4</sub>	C <sub>3</sub>	C <sub>2</sub>	C <sub>1</sub>	C <sub>0</sub>																
0	0	1F	0	0	0	1	1	1	1	1	IC revision Read	Read IC revision [POR 0x0D]														
1	1		A <sub>7</sub>	A <sub>6</sub>	A <sub>5</sub>	A <sub>4</sub>	A <sub>3</sub>	A <sub>2</sub>	A <sub>1</sub>	A <sub>0</sub>																

DATE NOV.06.2020	Version	1.0	TECHNICAL SPECIFICATION
LCM	YES	YMS152152-0150BABMFGN-R	Page 17 of 37

Command Table																												
R/W#	D/C#	Hex	D7	D6	D5	D4	D3	D2	D1	D0	Command	Description																
0	0	20	0	0	1	0	0	0	0	0	Master Activation	<p>Activate Display Update Sequence</p> <p>The Display Update Sequence Option is located at R22h.</p> <p>BUSY pad will output high during operation. User should not interrupt this operation to avoid corruption of panel images.</p>																
0	0	21	0	0	1	0	0	0	0	1	Display Update Control 1	<p>RAM content option for Display Update A[7:0] = 00h [POR] B[7:0] = 00h [POR]</p> <p>A[7:4] Red RAM option</p> <table border="1"> <tr><td>0000</td><td>Normal</td></tr> <tr><td>0100</td><td>Bypass RAM content as 0</td></tr> <tr><td>1000</td><td>Inverse RAM content</td></tr> </table> <p>A[3:0] BW RAM option</p> <table border="1"> <tr><td>0000</td><td>Normal</td></tr> <tr><td>0100</td><td>Bypass RAM content as 0</td></tr> <tr><td>1000</td><td>Inverse RAM content</td></tr> </table> <p>B[7] Source Output Mode</p> <table border="1"> <tr><td>0</td><td>Available Source from S0 to S175</td></tr> <tr><td>1</td><td>Available Source from S8 to S167</td></tr> </table>	0000	Normal	0100	Bypass RAM content as 0	1000	Inverse RAM content	0000	Normal	0100	Bypass RAM content as 0	1000	Inverse RAM content	0	Available Source from S0 to S175	1	Available Source from S8 to S167
0000	Normal																											
0100	Bypass RAM content as 0																											
1000	Inverse RAM content																											
0000	Normal																											
0100	Bypass RAM content as 0																											
1000	Inverse RAM content																											
0	Available Source from S0 to S175																											
1	Available Source from S8 to S167																											
0	1		A <sub>7</sub>	A <sub>6</sub>	A <sub>5</sub>	A <sub>4</sub>	A <sub>3</sub>	A <sub>2</sub>	A <sub>1</sub>	A <sub>0</sub>																		
0	1		B <sub>7</sub>	0	0	0	0	0	0	0																		
0	0	24	0	0	1	0	0	1	0	0	Write RAM (Black White) / RAM 0x24	<p>After this command, data entries will be written into the BW RAM until another command is written. Address pointers will advance accordingly</p> <p>For Write pixel: Content of Write RAM(BW) = 1</p> <p>For Black pixel: Content of Write RAM(BW) = 0</p>																

DATE NOV.06.2020	Version	1.0	TECHNICAL SPECIFICATION
LCM	YES	YMS152152-0150BABMFGN-R	Page 18 of 37

Command Table														
R/W#	D/C#	Hex	D7	D6	D5	D4	D3	D2	D1	D0	Command	Description		
0	0	22	0	0	1	0	0	0	1	0	Display Update Control 2	Display Update Sequence Option: Enable the stage for Master Activation A[7:0]= FFh (POR)		
0	1		A7	A6	A5	A4	A3	A2	A1	A0				
													<b>Operating sequence</b>	<b>Parameter (In Hex)</b>
													Enable clock signal	80
													Disable clock signal	01
													Enable clock signal → Enable Analog	C0
													Disable Analog → Disable clock signal	03
													Enable clock signal → Load LUT with DISPLAY Mode 1 → Disable clock signal	91
													Enable clock signal → Load LUT with DISPLAY Mode 2 → Disable clock signal	99
													Enable clock signal → Load temperature value → Load LUT with DISPLAY Mode 1 → Disable clock signal	B1
													Enable clock signal → Load temperature value → Load LUT with DISPLAY Mode 2 → Disable clock signal	B9
													Enable clock signal → Enable Analog → Display with DISPLAY Mode 1 → Disable Analog → Disable OSC	C7
													Enable clock signal → Enable Analog → Display with DISPLAY Mode 2 → Disable Analog → Disable OSC	CF
													Enable clock signal → Enable Analog → Load temperature value → DISPLAY with DISPLAY Mode 1 → Disable Analog → Disable OSC	F7
													Enable clock signal → Enable Analog → Load temperature value → DISPLAY with DISPLAY Mode 2 → Disable Analog → Disable OSC	FF
0	0	26	0	0	1	0	0	1	1	0	Write RAM (RED) / RAM 0x26	After this command, data entries will be written into the RED RAM until another command is written. Address pointers will advance accordingly.  For Red pixel: Content of Write RAM(RED) = 1 For non-Red pixel [Black or White]: Content of Write RAM(RED) = 0		
0	0	27	0	0	1	0	0	1	1	1	Read RAM	After this command, data read on the MCU bus will fetch data from RAM. According to parameter of Register 41h to select reading RAM0x24/ RAM0x26, until another command is written. Address pointers will advance accordingly.  The 1 <sup>st</sup> byte of data read is dummy data.		

DATE NOV.06.2020	Version	1.0	TECHNICAL SPECIFICATION
LCM	YES	YMS152152-0150BABMFGN-R	Page 19 of 37



Command Table																																																																												
R/W#	D/C#	Hex	D7	D6	D5	D4	D3	D2	D1	D0	Command	Description																																																																
0	0	28	0	0	1	0	1	0	0	0	VCOM Sense	<p>Enter VCOM sensing conditions and hold for duration defined in 29h before reading VCOM value.</p> <p>The sensed VCOM voltage is stored in register</p> <p>The command required CLKEN=1 and ANALOGEN=1</p> <p>Refer to Register 0x22 for detail.</p> <p>BUSY pad will output high during operation.</p>																																																																
0	0	29	0	0	1	0	1	0	0	1	VCOM Sense Duration	<p>Stabling time between entering VCOM sensing mode and reading acquired.</p> <p>A[3:0] = 9h, duration = 10s. VCOM sense duration = (A[3:0]+1) sec</p>																																																																
0	1		0	1	0	0	A <sub>3</sub>	A <sub>2</sub>	A <sub>1</sub>	A <sub>0</sub>																																																																		
0	0	2A	0	0	1	0	1	0	1	0	Program VCOM OTP	<p>Program VCOM register into OTP</p> <p>The command required CLKEN=1.</p> <p>Refer to Register 0x22 for detail.</p> <p>BUSY pad will output high during operation.</p>																																																																
0	0	2C	0	0	1	0	1	1	0	0	Write VCOM register	<p>Write VCOM register from MCU interface</p> <p>A[7:0] = 00h [POR]</p> <table border="1"> <thead> <tr> <th>A[7:0]</th> <th>VCOM</th> <th>A[7:0]</th> <th>VCOM</th> </tr> </thead> <tbody> <tr><td>08h</td><td>-0.2</td><td>44h</td><td>-1.7</td></tr> <tr><td>0Ch</td><td>-0.3</td><td>48h</td><td>-1.8</td></tr> <tr><td>10h</td><td>-0.4</td><td>4Ch</td><td>-1.9</td></tr> <tr><td>14h</td><td>-0.5</td><td>50h</td><td>-2</td></tr> <tr><td>18h</td><td>-0.6</td><td>54h</td><td>-2.1</td></tr> <tr><td>1Ch</td><td>-0.7</td><td>58h</td><td>-2.2</td></tr> <tr><td>20h</td><td>-0.8</td><td>5Ch</td><td>-2.3</td></tr> <tr><td>24h</td><td>-0.9</td><td>60h</td><td>-2.4</td></tr> <tr><td>28h</td><td>-1</td><td>64h</td><td>-2.5</td></tr> <tr><td>2Ch</td><td>-1.1</td><td>68h</td><td>-2.6</td></tr> <tr><td>30h</td><td>-1.2</td><td>6Ch</td><td>-2.7</td></tr> <tr><td>34h</td><td>-1.3</td><td>70h</td><td>-2.8</td></tr> <tr><td>38h</td><td>-1.4</td><td>74h</td><td>-2.9</td></tr> <tr><td>3Ch</td><td>-1.5</td><td>78h</td><td>-3</td></tr> <tr><td>40h</td><td>-1.6</td><td>Other</td><td>NA</td></tr> </tbody> </table>	A[7:0]	VCOM	A[7:0]	VCOM	08h	-0.2	44h	-1.7	0Ch	-0.3	48h	-1.8	10h	-0.4	4Ch	-1.9	14h	-0.5	50h	-2	18h	-0.6	54h	-2.1	1Ch	-0.7	58h	-2.2	20h	-0.8	5Ch	-2.3	24h	-0.9	60h	-2.4	28h	-1	64h	-2.5	2Ch	-1.1	68h	-2.6	30h	-1.2	6Ch	-2.7	34h	-1.3	70h	-2.8	38h	-1.4	74h	-2.9	3Ch	-1.5	78h	-3	40h	-1.6	Other	NA
A[7:0]	VCOM	A[7:0]	VCOM																																																																									
08h	-0.2	44h	-1.7																																																																									
0Ch	-0.3	48h	-1.8																																																																									
10h	-0.4	4Ch	-1.9																																																																									
14h	-0.5	50h	-2																																																																									
18h	-0.6	54h	-2.1																																																																									
1Ch	-0.7	58h	-2.2																																																																									
20h	-0.8	5Ch	-2.3																																																																									
24h	-0.9	60h	-2.4																																																																									
28h	-1	64h	-2.5																																																																									
2Ch	-1.1	68h	-2.6																																																																									
30h	-1.2	6Ch	-2.7																																																																									
34h	-1.3	70h	-2.8																																																																									
38h	-1.4	74h	-2.9																																																																									
3Ch	-1.5	78h	-3																																																																									
40h	-1.6	Other	NA																																																																									
0	1		A <sub>7</sub>	A <sub>6</sub>	A <sub>5</sub>	A <sub>4</sub>	A <sub>3</sub>	A <sub>2</sub>	A <sub>1</sub>	A <sub>0</sub>																																																																		

DATE NOV.06.2020	Version	1.0	TECHNICAL SPECIFICATION
LCM	YES	YMS152152-0150BABMFGN-R	Page 20 of 37

Command Table											Command	Description
R/W#	D/C#	Hex	D7	D6	D5	D4	D3	D2	D1	D0		
0	0	2D	0	0	1	0	1	1	0	1	OTP Register Read for Display Option	Read Register for Display Option:  A[7:0]: VCOM OTP Selection (Command 0x37, Byte A)  B[7:0]: VCOM Register (Command 0x2C)  C[7:0]~G[7:0]: Display Mode (Command 0x37, Byte B to Byte F) [5 bytes]  H[7:0]~K[7:0]: Waveform Version (Command 0x37, Byte G to Byte J) [4 bytes]
1	1		A7	A6	A5	A4	A3	A2	A1	A0		
1	1		B7	B6	B5	B4	B3	B2	B1	B0		
1	1		C7	C6	C5	C4	C3	C2	C1	C0		
1	1		D7	D6	D5	D4	D3	D2	D1	D0		
1	1		E7	E6	E5	E4	E3	E2	E1	E0		
1	1		F7	F6	F5	F4	F3	F2	F1	F0		
1	1		G7	G6	G5	G4	G3	G2	G1	G0		
1	1		H7	H6	H5	H4	H3	H2	H1	H0		
1	1		I7	I6	I5	I4	I3	I2	I1	I0		
1	1		J7	J6	J5	J4	J3	J2	J1	J0		
1	1		K7	K6	K5	K4	K3	K2	K1	K0		
0	0	2E	0	0	1	0	1	1	1	0	User ID Read	Read 10 Byte User ID stored in OTP: A[7:0]~J[7:0]: UserID (R38, Byte A and Byte J) [10 bytes]
1	1		A7	A6	A5	A4	A3	A2	A1	A0		
1	1		B7	B6	B5	B4	B3	B2	B1	B0		
1	1		C7	C6	C5	C4	C3	C2	C1	C0		
1	1		D7	D6	D5	D4	D3	D2	D1	D0		
1	1		E7	E6	E5	E4	E3	E2	E1	E0		
1	1		F7	F6	F5	F4	F3	F2	F1	F0		
1	1		G7	G6	G5	G4	G3	G2	G1	G0		
1	1		H7	H6	H5	H4	H3	H2	H1	H0		
1	1		I7	I6	I5	I4	I3	I2	I1	I0		
1	1		J7	J6	J5	J4	J3	J2	J1	J0		
0	0	2F	0	0	1	0	1	1	1	1		
1	1		0	0	A5	A4	0	0	A1	A0		
0	0	30	0	0	1	1	0	0	0	0	Program WS OTP	Program OTP of Waveform Setting The contents should be written into RAM before sending this command.  The command required CLKEN=1. Refer to Register 0x22 for detail. BUSY pad will output high during operation.

DATE NOV.06.2020	Version	1.0	TECHNICAL SPECIFICATION
LCM	YES	YMS152152-0150BABMFGN-R	Page 21 of 37



**Command Table**

R/W#	D/C#	Hex	D7	D6	D5	D4	D3	D2	D1	D0	Command	Description
0	0	31	0	0	1	1	0	0	0	1	Load WS OTP	<p>Load OTP of Waveform Setting</p> <p>The command required CLKEN=1. Refer to Register 0x22 for detail.</p> <p>BUSY pad will output high during operation.</p>
0	0	32	0	0	1	1	0	0	1	0	Write LUT register	<p>Write LUT register from MCU interface [227 bytes], which contains the content of VS[nX-LUTm], TP[nX], RP[n], SR[nXY], FR and XON[nXY]</p> <p>Refer to Session 6.7 WAVEFORM SETTING</p>
0	1		A <sub>7</sub>	A <sub>6</sub>	A <sub>5</sub>	A <sub>4</sub>	A <sub>3</sub>	A <sub>2</sub>	A <sub>1</sub>	A <sub>0</sub>		
0	1		B <sub>7</sub>	B <sub>6</sub>	B <sub>5</sub>	B <sub>4</sub>	B <sub>3</sub>	B <sub>2</sub>	B <sub>1</sub>	B <sub>0</sub>		
0	1		:	:	:	:	:	:	:	:		
0	1		.	.	.	.	.	.	.	.		
0	0	34	0	0	1	1	0	1	0	0	CRC calculation	<p>CRC calculation command</p> <p>For details, please refer to SSD1680A application note.</p> <p>BUSY pad will output high during operation.</p>
0	0	35	0	0	1	1	0	1	0	1	CRC Status Read	<p>CRC Status Read</p> <p>A[15:0] is the CRC read out value</p>
1	1		A <sub>15</sub>	A <sub>14</sub>	A <sub>13</sub>	A <sub>12</sub>	A <sub>11</sub>	A <sub>10</sub>	A <sub>9</sub>	A <sub>8</sub>		
1	1		A <sub>7</sub>	A <sub>6</sub>	A <sub>5</sub>	A <sub>4</sub>	A <sub>3</sub>	A <sub>2</sub>	A <sub>1</sub>	A <sub>0</sub>		
0	0	36	0	0	1	1	0	1	1	0	Program OTP selection	<p>Program OTP Selection according to the OTP Selection Control [R37h and R38h]</p> <p>The command required CLKEN=1. Refer to Register 0x22 for detail. BUSY pad will output high during operation.</p>
0	0	37	0	0	1	1	0	1	1	1	Write Register for Display Option	<p>Write Register for Display Option</p> <p>A[7] Spare VCOM OTP selection</p> <p>0: Default [POR]</p> <p>1: Spare</p> <p>B[7:0] Display Mode for WS[7:0]</p> <p>C[7:0] Display Mode for WS[15:8]</p> <p>D[7:0] Display Mode for WS[23:16]</p> <p>0: Display Mode 1</p> <p>1: Display Mode 2</p> <p>F[6]: Ping-Pong for Display Mode 2</p> <p>0: RAM Ping-Pong disable [POR]</p> <p>1: RAM Ping-Pong enable</p> <p>G[7:0]~J[7:0] module ID /waveform version.</p> <p>Remarks:</p> <p>1) A[7:0]~J[7:0] can be stored in OTP</p> <p>2) RAM Ping-Pong function is not support for Display Mode 1</p>
0	1		A <sub>7</sub>	0	0	0	0	0	0	0		
0	1		B <sub>7</sub>	B <sub>6</sub>	B <sub>5</sub>	B <sub>4</sub>	B <sub>3</sub>	B <sub>2</sub>	B <sub>1</sub>	B <sub>0</sub>		
0	1		C <sub>7</sub>	C <sub>6</sub>	C <sub>5</sub>	C <sub>4</sub>	C <sub>3</sub>	C <sub>2</sub>	C <sub>1</sub>	C <sub>0</sub>		
0	1		D <sub>7</sub>	D <sub>6</sub>	D <sub>5</sub>	D <sub>4</sub>	D <sub>3</sub>	D <sub>2</sub>	D <sub>1</sub>	D <sub>0</sub>		
0	1		E <sub>7</sub>	E <sub>6</sub>	E <sub>5</sub>	E <sub>4</sub>	E <sub>3</sub>	E <sub>2</sub>	E <sub>1</sub>	E <sub>0</sub>		
0	1		0	F <sub>6</sub>	0	0	F <sub>3</sub>	F <sub>2</sub>	F <sub>1</sub>	F <sub>0</sub>		
0	1		G <sub>7</sub>	G <sub>6</sub>	G <sub>5</sub>	G <sub>4</sub>	G <sub>3</sub>	G <sub>2</sub>	G <sub>1</sub>	G <sub>0</sub>		
0	1		H <sub>7</sub>	H <sub>6</sub>	H <sub>5</sub>	H <sub>4</sub>	H <sub>3</sub>	H <sub>2</sub>	H <sub>1</sub>	H <sub>0</sub>		
0	1		I <sub>7</sub>	I <sub>6</sub>	I <sub>5</sub>	I <sub>4</sub>	I <sub>3</sub>	I <sub>2</sub>	I <sub>1</sub>	I <sub>0</sub>		
0	1		J <sub>7</sub>	J <sub>6</sub>	J <sub>5</sub>	J <sub>4</sub>	J <sub>3</sub>	J <sub>2</sub>	J <sub>1</sub>	J <sub>0</sub>		

DATE NOV.06.2020	Version	1.0	TECHNICAL SPECIFICATION
LCM	YES	YMS152152-0150BABMFGN-R	Page 22 of 37

Command Table																																										
R/W#	D/C#	Hex	D7	D6	D5	D4	D3	D2	D1	D0	Command	Description																														
0	0	38	0	0	1	1	1	0	0	0	Write Register for User ID	Write Register for User ID A[7:0]~J[7:0]: UserID [10 bytes]  Remarks: A[7:0]~J[7:0] can be stored in OTP																														
0	1		A <sub>7</sub>	A <sub>6</sub>	A <sub>5</sub>	A <sub>4</sub>	A <sub>3</sub>	A <sub>2</sub>	A <sub>1</sub>	A <sub>0</sub>																																
0	1		B <sub>7</sub>	B <sub>6</sub>	B <sub>5</sub>	B <sub>4</sub>	B <sub>3</sub>	B <sub>2</sub>	B <sub>1</sub>	B <sub>0</sub>																																
0	1		C <sub>7</sub>	C <sub>6</sub>	C <sub>5</sub>	C <sub>4</sub>	C <sub>3</sub>	C <sub>2</sub>	C <sub>1</sub>	C <sub>0</sub>																																
0	1		D <sub>7</sub>	D <sub>6</sub>	D <sub>5</sub>	D <sub>4</sub>	D <sub>3</sub>	D <sub>2</sub>	D <sub>1</sub>	D <sub>0</sub>																																
0	1		E <sub>7</sub>	E <sub>6</sub>	E <sub>5</sub>	E <sub>4</sub>	E <sub>3</sub>	E <sub>2</sub>	E <sub>1</sub>	E <sub>0</sub>																																
0	1		F <sub>7</sub>	F <sub>6</sub>	F <sub>5</sub>	F <sub>4</sub>	F <sub>3</sub>	F <sub>2</sub>	F <sub>1</sub>	F <sub>0</sub>																																
0	1		G <sub>7</sub>	G <sub>6</sub>	G <sub>5</sub>	G <sub>4</sub>	G <sub>3</sub>	G <sub>2</sub>	G <sub>1</sub>	G <sub>0</sub>																																
0	1		H <sub>7</sub>	H <sub>6</sub>	H <sub>5</sub>	H <sub>4</sub>	H <sub>3</sub>	H <sub>2</sub>	H <sub>1</sub>	H <sub>0</sub>																																
0	1		I <sub>7</sub>	I <sub>6</sub>	I <sub>5</sub>	I <sub>4</sub>	I <sub>3</sub>	I <sub>2</sub>	I <sub>1</sub>	I <sub>0</sub>																																
0	1		J <sub>7</sub>	J <sub>6</sub>	J <sub>5</sub>	J <sub>4</sub>	J <sub>3</sub>	J <sub>2</sub>	J <sub>1</sub>	J <sub>0</sub>																																
0	0	39	0	0	1	1	1	0	0	1	OTP program mode	OTP program mode A[1:0] = 00: Normal Mode [POR] A[1:0] = 11: Internal generated OTP programming voltage  : User is required to EXACTLY follow the reference code sequences																														
0	1		0	0	0	0	0	0	A <sub>1</sub>	A <sub>0</sub>																																
0	0	3C	0	0	1	1	1	1	0	0	Border Waveform Control	Select border waveform for VBD A[7:0] = C0h [POR], set VBD as HiZ. A [7:6] :Select VBD option <table border="1" style="width: 100%;"> <tr> <td>A[7:6]</td> <td>Select VBD as</td> </tr> <tr> <td>00</td> <td>GS Transition, Defined in A[2] and A[1:0]</td> </tr> <tr> <td>01</td> <td>Fix Level, Defined in A[5:4]</td> </tr> <tr> <td>10</td> <td>VCOM</td> </tr> <tr> <td>11[POR]</td> <td>HiZ</td> </tr> </table> A [5:4] Fix Level Setting for VBD <table border="1" style="width: 100%;"> <tr> <td>A[5:4]</td> <td>VBD level</td> </tr> <tr> <td>00</td> <td>VSS</td> </tr> <tr> <td>01</td> <td>VSH1</td> </tr> <tr> <td>10</td> <td>VSL</td> </tr> <tr> <td>11</td> <td>VSH2</td> </tr> </table> A [1:0] GS Transition setting for VBD VBD Level Selection: 00b: VCOM ; 01b: VSH1; 10b: VSL; 11b: VSH2 <table border="1" style="width: 100%;"> <tr> <td>A[1:0]</td> <td>VBD Transition</td> </tr> <tr> <td>00</td> <td>LUT0</td> </tr> <tr> <td>01</td> <td>LUT1</td> </tr> <tr> <td>10</td> <td>LUT2</td> </tr> <tr> <td>11</td> <td>LUT3</td> </tr> </table>	A[7:6]	Select VBD as	00	GS Transition, Defined in A[2] and A[1:0]	01	Fix Level, Defined in A[5:4]	10	VCOM	11[POR]	HiZ	A[5:4]	VBD level	00	VSS	01	VSH1	10	VSL	11	VSH2	A[1:0]	VBD Transition	00	LUT0	01	LUT1	10	LUT2	11	LUT3
A[7:6]	Select VBD as																																									
00	GS Transition, Defined in A[2] and A[1:0]																																									
01	Fix Level, Defined in A[5:4]																																									
10	VCOM																																									
11[POR]	HiZ																																									
A[5:4]	VBD level																																									
00	VSS																																									
01	VSH1																																									
10	VSL																																									
11	VSH2																																									
A[1:0]	VBD Transition																																									
00	LUT0																																									
01	LUT1																																									
10	LUT2																																									
11	LUT3																																									
0	1		A <sub>7</sub>	A <sub>6</sub>	A <sub>5</sub>	A <sub>4</sub>	0	0	A <sub>1</sub>	A <sub>0</sub>																																
0	0	3F	0	0	1	1	1	1	1	1	End Option (EOPT)	Option for LUT end Data bytes should be set for this command or programmed into Waveform setting. <table border="1" style="width: 100%;"> <tr> <td>22h</td> <td>Normal.</td> </tr> <tr> <td>07h</td> <td>Source output level keep previous output before power off</td> </tr> </table>	22h	Normal.	07h	Source output level keep previous output before power off																										
22h	Normal.																																									
07h	Source output level keep previous output before power off																																									
0	1		A <sub>7</sub>	A <sub>6</sub>	A <sub>5</sub>	A <sub>4</sub>	A <sub>3</sub>	A <sub>2</sub>	A <sub>1</sub>	A <sub>0</sub>																																

DATE NOV.06.2020	Version	1.0	TECHNICAL SPECIFICATION
LCM	YES	YMS152152-0150BABMFGN-R	Page 23 of 37



Command Table												Command	Description																				
R/W#	D/C#	Hex	D7	D6	D5	D4	D3	D2	D1	D0																							
0	0	41	0	1	0	0	0	0	0	1		Read RAM Option	Read RAM Option A[0]= 0 [POR] 0 : Read RAM corresponding to RAM0x24 1 : Read RAM corresponding to RAM0x26																				
0	1		0	0	0	0	0	0	0	A <sub>0</sub>																							
0	0	44	0	1	0	0	0	1	0	0		Set RAM X - address Start / End position	Specify the start/end positions of the window address in the X direction by an address unit for RAM  A[5:0]: XSA[5:0], XStart, POR = 00h B[5:0]: XEA[5:0], XEnd, POR = 15h																				
0	1		0	0	A <sub>5</sub>	A <sub>4</sub>	A <sub>3</sub>	A <sub>2</sub>	A <sub>1</sub>	A <sub>0</sub>																							
0	1		0	0	B <sub>5</sub>	B <sub>4</sub>	B <sub>3</sub>	B <sub>2</sub>	B <sub>1</sub>	B <sub>0</sub>																							
0	0	45	0	1	0	0	0	1	0	1		Set Ram Y- address Start / End position	Specify the start/end positions of the window address in the Y direction by an address unit for RAM  A[8:0]: YSA[8:0], YStart, POR = 000h B[8:0]: YEA[8:0], YEnd, POR = 127h																				
0	1		A <sub>7</sub>	A <sub>6</sub>	A <sub>5</sub>	A <sub>4</sub>	A <sub>3</sub>	A <sub>2</sub>	A <sub>1</sub>	A <sub>0</sub>																							
0	1		0	0	0	0	0	0	0	A <sub>8</sub>																							
0	1		B <sub>7</sub>	B <sub>6</sub>	B <sub>5</sub>	B <sub>4</sub>	B <sub>3</sub>	B <sub>2</sub>	B <sub>1</sub>	B <sub>0</sub>																							
0	1		0	0	0	0	0	0	0	B <sub>8</sub>																							
0	0	46	0	1	0	0	0	1		0		Auto Write RED RAM for Regular Pattern	Auto Write RED RAM for Regular Pattern A[7:0] = 00h [POR]  A[7]: The 1st step value, POR = 0 A[6:4]: Step Height, POR= 000 Step of alter RAM in Y-direction according to Gate																				
0	1		A <sub>7</sub>	A <sub>6</sub>	A <sub>5</sub>	A <sub>4</sub>	0	A <sub>2</sub>	A <sub>1</sub>	A <sub>0</sub>																							
													<table border="1"> <thead> <tr> <th>A[6:4]</th> <th>Height</th> <th>A[6:4]</th> <th>Height</th> </tr> </thead> <tbody> <tr> <td>000</td> <td>8</td> <td>100</td> <td>128</td> </tr> <tr> <td>001</td> <td>16</td> <td>101</td> <td>256</td> </tr> <tr> <td>010</td> <td>32</td> <td>110</td> <td>296</td> </tr> <tr> <td>011</td> <td>64</td> <td>111</td> <td>NA</td> </tr> </tbody> </table>	A[6:4]	Height	A[6:4]	Height	000	8	100	128	001	16	101	256	010	32	110	296	011	64	111	NA
A[6:4]	Height	A[6:4]	Height																														
000	8	100	128																														
001	16	101	256																														
010	32	110	296																														
011	64	111	NA																														
													<p>A[2:0]: Step Width, POR= 000 Step of alter RAM in X-direction according to Source</p> <table border="1"> <thead> <tr> <th>A[2:0]</th> <th>Width</th> <th>A[2:0]</th> <th>Width</th> </tr> </thead> <tbody> <tr> <td>000</td> <td>8</td> <td>100</td> <td>128</td> </tr> <tr> <td>001</td> <td>16</td> <td>101</td> <td>176</td> </tr> <tr> <td>010</td> <td>32</td> <td>110</td> <td>NA</td> </tr> <tr> <td>011</td> <td>64</td> <td>111</td> <td>NA</td> </tr> </tbody> </table>	A[2:0]	Width	A[2:0]	Width	000	8	100	128	001	16	101	176	010	32	110	NA	011	64	111	NA
A[2:0]	Width	A[2:0]	Width																														
000	8	100	128																														
001	16	101	176																														
010	32	110	NA																														
011	64	111	NA																														
													BUSY pad will output high during operation.																				

DATE NOV.06.2020	Version	1.0	TECHNICAL SPECIFICATION
LCM	YES	YMS152152-0150BABMFGN-R	Page 24 of 37



Command Table																																																				
R/W#	D/C#	Hex	D7	D6	D5	D4	D3	D2	D1	D0	Command	Description																																								
0	0	47	0	1	0	0	0	1	1	1	Auto Write B/W RAM for Regular Pattern	Auto Write B/W RAM for Regular Pattern A[7:0] = 00h [POR]  A[7]: The 1st step value, POR = 0 A[6:4]: Step Height, POR= 000 Step of alter RAM in Y-direction according to Gate <table border="1"> <thead> <tr> <th>A[6:4]</th> <th>Height</th> <th>A[6:4]</th> <th>Height</th> </tr> </thead> <tbody> <tr> <td>000</td> <td>8</td> <td>100</td> <td>128</td> </tr> <tr> <td>001</td> <td>16</td> <td>101</td> <td>256</td> </tr> <tr> <td>010</td> <td>32</td> <td>110</td> <td>296</td> </tr> <tr> <td>011</td> <td>64</td> <td>111</td> <td>NA</td> </tr> </tbody> </table>  A[2:0]: Step Width, POR= 000 Step of alter RAM in X-direction according to Source <table border="1"> <thead> <tr> <th>A[2:0]</th> <th>Width</th> <th>A[2:0]</th> <th>Width</th> </tr> </thead> <tbody> <tr> <td>000</td> <td>8</td> <td>100</td> <td>128</td> </tr> <tr> <td>001</td> <td>16</td> <td>101</td> <td>176</td> </tr> <tr> <td>010</td> <td>32</td> <td>110</td> <td>NA</td> </tr> <tr> <td>011</td> <td>64</td> <td>111</td> <td>NA</td> </tr> </tbody> </table> During operation, BUSY pad will output high.	A[6:4]	Height	A[6:4]	Height	000	8	100	128	001	16	101	256	010	32	110	296	011	64	111	NA	A[2:0]	Width	A[2:0]	Width	000	8	100	128	001	16	101	176	010	32	110	NA	011	64	111	NA
A[6:4]	Height	A[6:4]	Height																																																	
000	8	100	128																																																	
001	16	101	256																																																	
010	32	110	296																																																	
011	64	111	NA																																																	
A[2:0]	Width	A[2:0]	Width																																																	
000	8	100	128																																																	
001	16	101	176																																																	
010	32	110	NA																																																	
011	64	111	NA																																																	
0	1		A <sub>7</sub>	A <sub>6</sub>	A <sub>5</sub>	A <sub>4</sub>	0	A <sub>2</sub>	A <sub>1</sub>	A <sub>0</sub>																																										
0	0	4E	0	1	0	0	1	1	1	0	Set RAM X address counter	Make initial settings for the RAM X address in the address counter (AC) A[5:0]: 00h [POR].																																								
0	1		0	0	A <sub>5</sub>	A <sub>4</sub>	A <sub>3</sub>	A <sub>2</sub>	A <sub>1</sub>	A <sub>0</sub>																																										
0	0	4F	0	1	0	0	1	1	1	1	Set RAM Y address counter	Make initial settings for the RAM Y address in the address counter (AC) A[8:0]: 000h [POR].																																								
0	1		A <sub>7</sub>	A <sub>6</sub>	A <sub>5</sub>	A <sub>4</sub>	A <sub>3</sub>	A <sub>2</sub>	A <sub>1</sub>	A <sub>0</sub>																																										
0	1		0	0	0	0	0	0	0	A <sub>8</sub>																																										
0	0	7F	0	1	1	1	1	1	1	1	NOP	This command is an empty command; it does not have any effect on the display module. However it can be used to terminate Frame Memory Write or Read Commands.																																								

DATE NOV.06.2020	Version	1.0	TECHNICAL SPECIFICATION
LCM	YES	YMS152152-0150BABMFGN-R	Page 25 of 37

## 8. Optical Specifications

Measurements are made with that the illumination is under an angle of 45 degree, the detection is perpendicular unless otherwise specified

Symbol	Parameter	Conditions	Min	Typ.	Max	Units	Notes
R	White Reflectivity	White	30	35	-	%	8-1
CR	Contrast Ratio	Indoor	8:1		-		8-2
GN	2Grey Level	-		$DS+(WS-DS)*n(m-1)$			8-3
T update	Image update time	at 25 °C		16	-	sec	
Life		Topr		1000000times or 5years			

Notes: 8-1. Luminance meter: Eye-One Pro Spectrophotometer.

8-2. CR=Surface Reflectance with all white pixel/Surface Reflectance with all black pixels.

8-3. WS: White state, DS: Dark state

## 9. Handling, Safety and Environment Requirements

### Warning

The display glass may break when it is dropped or bumped on a hard surface. Handle with care. Should the display break, do not touch the electrophoretic material. In case of contact with electrophoretic material, wash with water and soap.

### Caution

The display module should not be exposed to harmful gases, such as acid and alkali gases, which corrode electronic components. Disassembling the display module.

Disassembling the display module can cause permanent damage and invalidates the warranty agreements.

Observe general precautions that are common to handling delicate electronic components. The glass can break and front surfaces can easily be damaged. Moreover the display is sensitive to static electricity and other rough environmental conditions.

Data sheet status	
Product specification	This data sheet contains final product specifications.
Limiting values	
Limiting values given are in accordance with the Absolute Maximum Rating System (IEC 134). Stress above one or more of the limiting values may cause permanent damage to the device. These are stress ratings only and operation of the device at these or at any other conditions above those given in the Characteristics sections of the specification is not implied. Exposure to limiting values for extended periods may affect device reliability.	
Application information	
Where application information is given, it is advisory and does not form part of the specification.	

DATE NOV.06.2020	Version	1.0	TECHNICAL SPECIFICATION
LCM	YES	YMS152152-0150BABMFGN-R	Page 26 of 37

## 10. Reliability test

NO	Test items	Test condition
1	Low-Temperature Storage	T = -25°C, 240 h Test in white pattern
2	High-Temperature Storage	T=70° C, RH=40%, 240h Test in white pattern
3	High-Temperature Operation	T=40° C, RH=35%, 240h
4	Low-Temperature Operation	0° C, 240h
5	High-Temperature, High-Humidity Operation	T=40° C, RH=80%, 240h
6	High Temperature, High Humidity Storage	T=50° C, RH=80%, 240h Test in white pattern
7	Temperature Cycle	1 cycle:[-25° C 30min]→[+70 ° C 30 min] : 50 cycles Test in white pattern
8	UV exposure Resistance	765W/m <sup>2</sup> for 168hrs,40 °C Test in white pattern
9	ESD Gun	Air+/-15KV;Contact+/-8KV (Test finished product shell, not display only) Air+/-8KV;Contact+/-6KV (Naked EPD display, no including IC and FPC area) Air+/-4KV;Contact+/-2KV (Naked EPD display, including IC and FPC area)

Note: Put in normal temperature for 1hour after test finished, display performance is ok.

DATE NOV.06.2020	Version	1.0	TECHNICAL SPECIFICATION
LCM	YES	YMS152152-0150BABMFGN-R	Page 27 of 37

11. Block Diagram

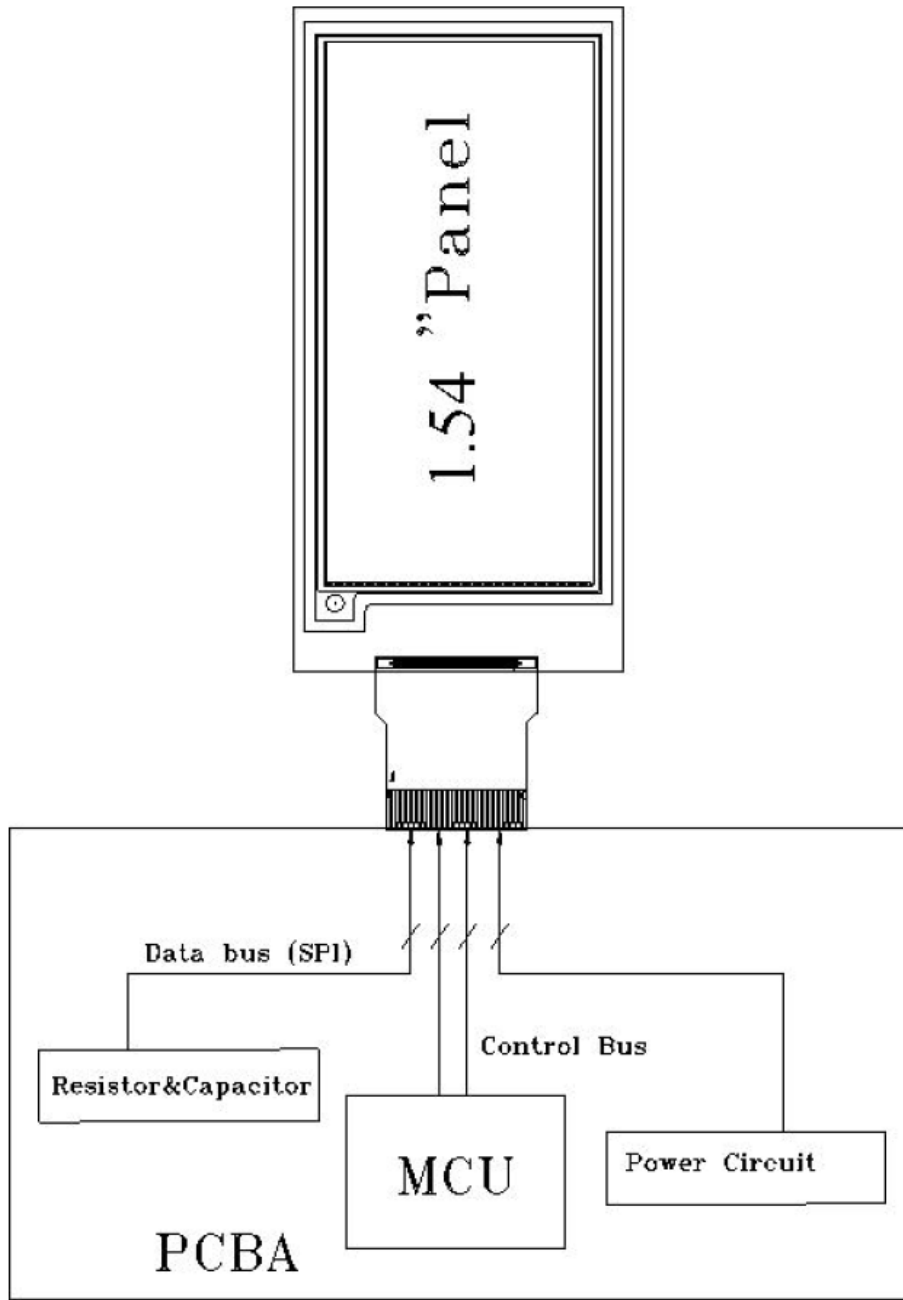

DATE NOV.06.2020	Version	1.0	TECHNICAL SPECIFICATION
LCM	YES	YMS152152-0150BABMFGN-R	Page 28 of 37

## 12. Typical Application Circuit with SPI Interface

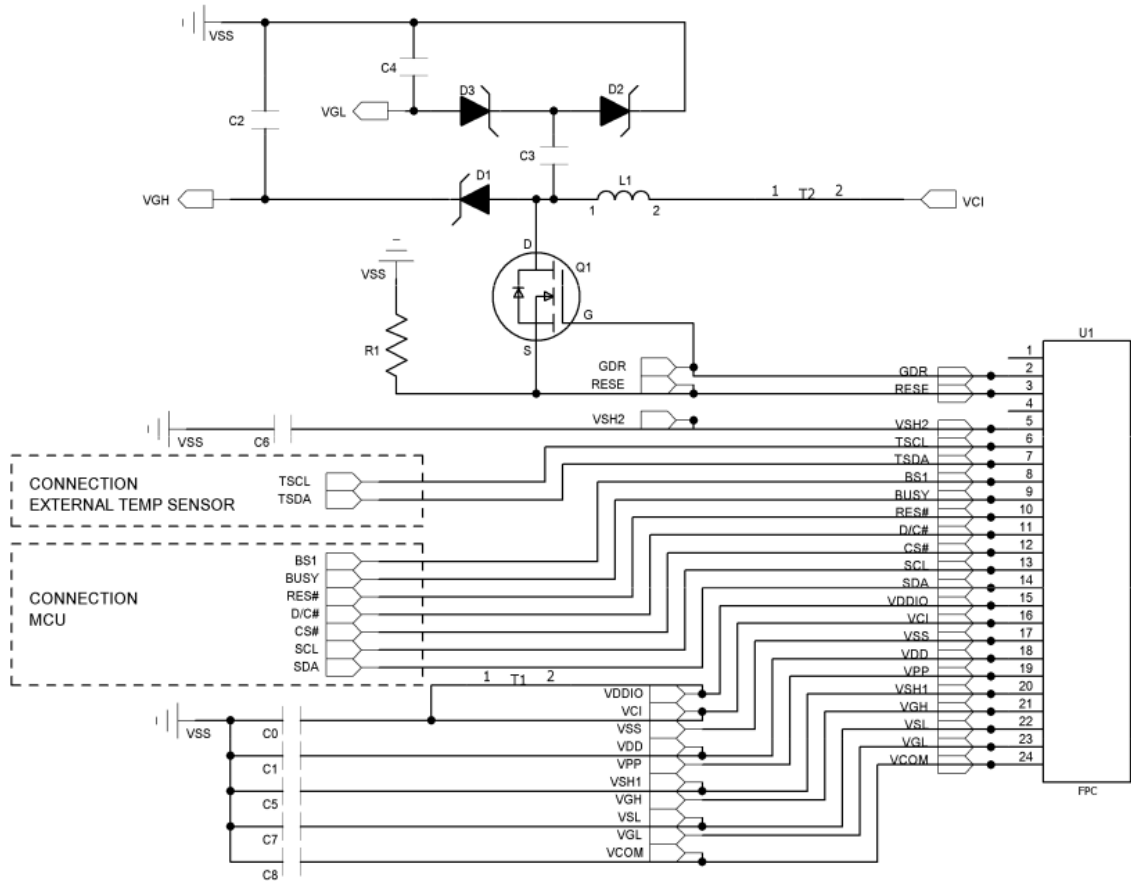

Part Name	Value	Requirements/Reference Part
C0-C1	1uF	X5R/X7R; Voltage Rating : 6V or 25V
C2-C7	1uF	0402/0603/0805; X5R/X7R; Voltage Rating : 25V
C8	0.47uF, 1uF	0402/0603/0805; X7R; Voltage Rating : 25V
R1	2.2 ohm	0402/0603/0805; 1% variation, ≥ 0.05W
D1-D3	Diode	MBR0530 1) Reverse DC voltage ≥ 30V 2) I <sub>o</sub> ≥ 500mA 3) Forward voltage ≤ 430mV
Q1	NMOS	Si1304BDL/NX3008NBK 1) Drain-Source breakdown voltage ≥ 30V 2) V <sub>gs(th)</sub> = 0.9V (Typ), 1.3V (Max) 3) R <sub>ds on</sub> ≤ 2.1Ω @ V <sub>gs</sub> = 2.5V
L1	47uH	CDRH2D18 / LDNP-470NC I <sub>o</sub> = 500mA (Max)
U1	0.5mm ZIF socket	24pins, 0.5mm pitch

DATE NOV.06.2020	Version	1.0	TECHNICAL SPECIFICATION
LCM	YES	YMS152152-0150BABMFGN-R	Page 29 of 37

## 13. Typical Operating Sequence

### 13.1 Normal Operation Flow

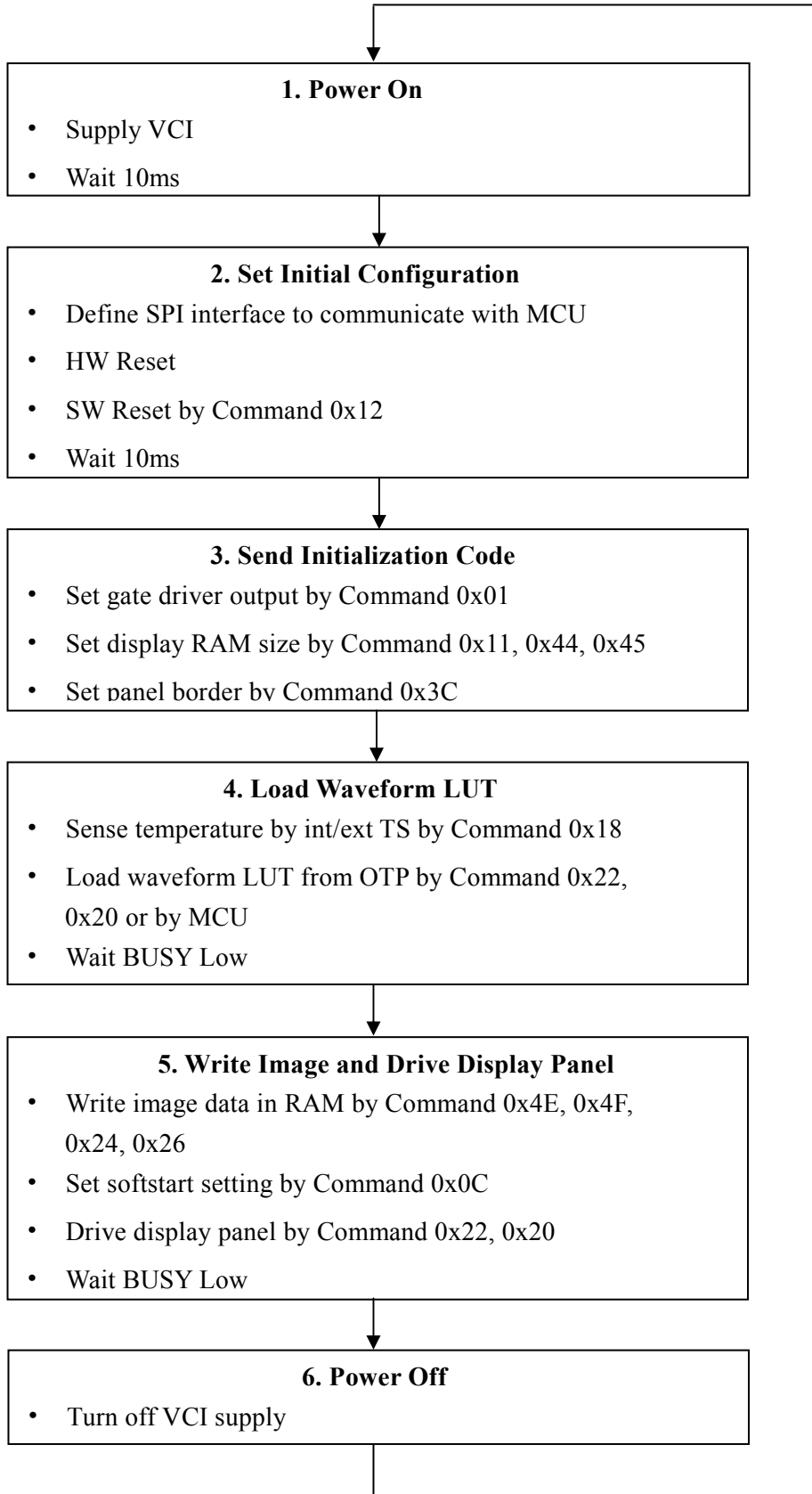

DATE NOV.06.2020	<b>Version</b>	<b>1.0</b>	TECHNICAL SPECIFICATION
<b>LCM</b>	<b>YES</b>	YMS152152-0150BABMFGN-R	Page 30 of 37

## 13.2 Normal Operation Reference Program Code

ACTION	VALUE/DATA	COMMENT
POWER ON		
delay	10ms	
PIN CONFIG		
RESE#	low	Hardware reset
delay	200us	
RESE#	high	
delay	200us	
Read busy pin		Wait for busy low
Command 0x12		Software reset
Read busy pin		Wait for busy low
Command 0x01	Data 0x97 0x00 0x00	Set display size and driver output control
Command 0x11	Data 0x01	Ram data entry mode
Command 0x44	Data 0x00 0x12	Set Ram X address
Command 0x45	Data 0x97 0x00 0x00 0x00	Set Ram Y address
Command 0x3C	Data 0x01	Set border
LOAD IMAGE AND UPDATE		
Command 0x4E	Data 0x00	Set Ram X address counter
Command 0x4F	Data 0x97 0x00	Set Ram Y address counter
Command 0x24	Data 0xXX... , 0xXX	Write B/W image data into to Register 0x24 RAM
Command 0x4E	Data 0x00	Set Ram X address counter
Command 0x4F	Data 0x97 0x00	Set Ram Y address counter
Command 0x26	Data 0xXX... , 0xXX	Write Red image data into Register 0x26 RAM
Command 0x20		
Read busy pin		
Command 0x10	Data 0X01	Enter deep sleep mode
POWER OFF		

DATE NOV.06.2020

Version

1.0

TECHNICAL SPECIFICATION

LCM

YES

YMS152152-0150BABMFGN-R

Page 31 of 37

### 13.3 OTP Operation Flow

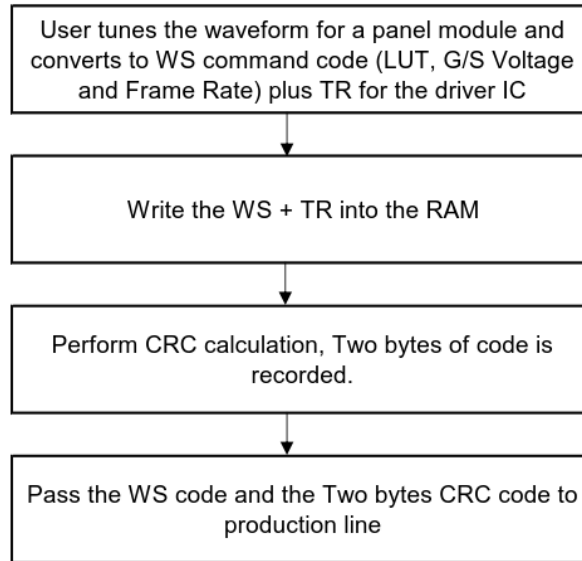

### 13.4 OTP Operation Reference Program Code

Procedure and Code sequence for WS & TR in the OTP			
Step	Action	Value/Data	Comment
1	Command 0x12		SWRESET
2	wait for BUSY LOW	bound by a timeout value	
3	Command 0x21	0x00 0x00	Display Update Control 1
4	Command 0x11	0x07	Data entry mode setting
5	Command 0x44	0x00 0x13	Set RAM X address
6	Command 0x45	0x00 0x00 0x27 0x01	Set RAM Y address
7	Command 0x4E	0x00	Set RAM X address counter = 0
8	Command 0x4F	0x00 0x00	Set RAM Y address counter = 0
9	Command 0x47	0x65	Clear RAM content as zero
10	wait for BUSY LOW	bound by a timeout value	
11	Command 0x22	0x80	Master Configuration: Enable Clock
12	Command 0x20		Master Activation
13	wait for BUSY LOW	bound by a timeout value	
14	Command 0x4E	0x00	Set RAM X address counter = 0
15	Command 0x4F	0x00 0x00	Set RAM Y address counter = 0
16	Command 0x24	RAM:5640 byte	Write Waveform setting and Temperature Range into RAM
17	Command 0x4E	0x00	Set RAM X address counter = 0
18	Command 0x4F	0x00 0x00	Set RAM Y address counter = 0
19	Command 0x34		CRC Calculation from (0x00,0x000) to (0x13,0x127), total 5920 byte
20	wait for BUSY LOW	bound by a timeout value	
21	Command 0x35	Parameter 1 Parameter 2	CRC Status Read Parameter 1 is Most-Significant Byte, Parameter 2 is Least-Significant Byte.
22		MCU records these two bytes CRC code for after-OTP checking	
23	Command 0x39	0x03	Set internal OTP programming voltage
24	Command 0x03	0x07	
25	Command 0x04	0xC1 0xA8 0x1A	
26	Command 0x22	0xC0	Master Configuration: Enable Analog and Clock
27	Command 0x20		Master Activation
28	wait for BUSY LOW	bound by a timeout value	
29	Command 0x4E	0x00 0x00	Set RAM X address counter = 0
30	Command 0x4F	0x00 0x00	Set RAM Y address counter = 0
31	Command 0x30		Program Waveform Setting and Temperature Range into OTP.
32	Command 0x22	0x03	Master Configuration: Disable Analog and Clock
33	Command 0x20		Master Activation
34	wait for BUSY LOW	bound by a timeout value	
35	Command 0x12		SWRESET
36	wait for BUSY LOW	bound by a timeout value	

DATE NOV.06.2020	Version	1.0	TECHNICAL SPECIFICATION
LCM	YES	YMS152152-0150BABMFGN-R	Page 32 of 37



## 14. Part Number Definition

TBD

## 15. Inspection condition

### 15. 1 Environment

Temperature: 25±3℃

Humidity: 55±10%RH

### 15. 2 Illuminance

Brightness:1200~1500LUX;distance:20-30CM;Angle:Relate 45° surround.

### 15.3 Inspection method

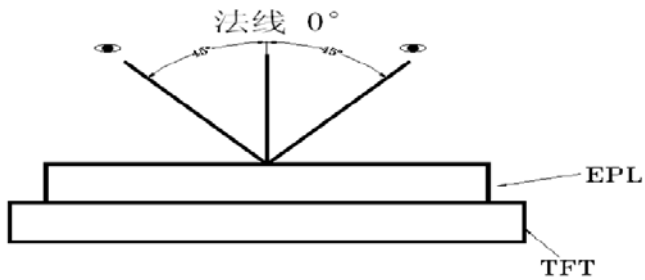

### 15. 4 Display area

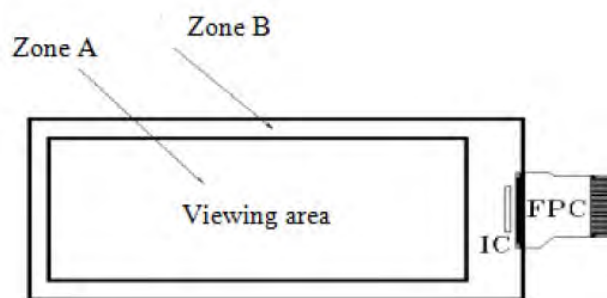

DATE NOV.06.2020	<b>Version</b>	<b>1.0</b>	TECHNICAL SPECIFICATION
<b>LCM</b>	<b>YES</b>	YMS152152-0150BABMFGN-R	Page 33 of 37

15. 5 Inspection standard

15. 5.1 Electric inspection standard

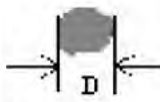
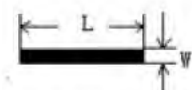

NO.	Item	Standard	Defect level	Method	Scope
1	Display	Display complete Display uniform	MA	Visual inspection  Visual/ Inspection card	Zone A
2	Black/White spots	 $D \leq 0.25\text{mm}$ , Allowed $0.25\text{mm} < D \leq 0.4\text{mm}$ , $N \leq 4$ , and Distance $\geq 5\text{mm}$ $0.4\text{mm} < D$ Not Allow	MI		
3	Black/White spots (No switch)	 $L \leq 0.4\text{mm}$ , $W \leq 0.1\text{mm}$ negligible $0.4\text{mm} < L \leq 1.0\text{mm}$ $0.1\text{mm} < W \leq 0.4\text{mm}$ $N \leq 4$ allowable $L > 1.0\text{mm}$ , $W > 0.4\text{mm}$ , Not Allow	MI		
4	Ghost image	Allowed in switching process	MI		
5	Flash spots/ Larger FPL size	Flash spots in switching, Allowed FPL size larger than viewing area, Allowed	MI		
6	Display wrong/Missing	All appointed displays are showed correct	MA		
7	Short circuit/ Circuit break/ Display abnormal	Not Allow			

DATE NOV.06.2020	Version	1.0	TECHNICAL SPECIFICATION
LCM	YES	YMS152152-0150BABMFGN-R	Page 34 of 37

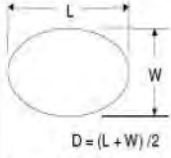
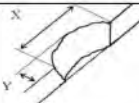
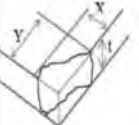
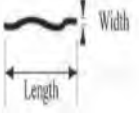
15.5.2 Appearance inspection standard

NO.	Item	Standard	Defect level	Method	Scope
1	B/W spots /Bubble/ Foreign bodies/ Dents	 <p><math>D = (L + W) / 2</math></p> <p><math>D \leq 0.25\text{mm}</math>, negligible  <math>0.25\text{mm} &lt; D \leq 0.4\text{mm}</math>, <math>N \leq 4</math> Allowed  <math>D &gt; 0.4\text{mm}</math>, Not Allow</p>	MI	Visual inspection	Zone A
2	Glass crack	Not Allow	MA	Visual / Microscope	Zone A Zone B
3	Dirty	Allowed if can be removed	MI		Zone A Zone B
4	Chips/Scratch/ Edge crown	 <p><math>X \leq 3\text{mm}, Y \leq 0.5\text{mm}</math> And without affecting the electrode is permissible</p>  <p><math>2\text{mm} \leq X</math> or <math>2\text{mm} \leq Y</math> Not Allow</p>  <p><math>W \leq 0.1\text{mm}, L \leq 5\text{mm}</math>, No harm to the electrodes and <math>N \leq 2</math> allow</p>	MI	Visual / Microscope	Zone A Zone B

DATE NOV.06.2020	Version	1.0	TECHNICAL SPECIFICATION
LCM	YES	YMS152152-0150BABMFGN-R	Page 35 of 37

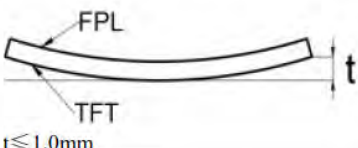
5	TFT Cracks	 Not Allow	MA	Visual / Microscope	Zone A Zone B
6	Dirty/ foreign body	Allowed if can be removed/ allow	MI	Visual / Microscope	Zone A / Zone B
7	FPC broken/ Goldfingers oxidation/ scratch	 Not Allow	MA	Visual / Microscope	Zone B
8	TFT edge bulge /TFT chromatic aberration	TFT edge bulge: $X \leq 3\text{mm}$ , $Y \leq 0.3\text{mm}$ Allowed TFT chromatic aberration :Allowed	MI	Visual / Microscope	Zone A Zone B
9	PCB damaged/ Poor welding/ Curl	PCB (Circuit area) damaged Not Allow PCB Poor welding Not Allow PCB Curl $\leq 1\%$			
10	Edge glue height/ Edge glue bubble	Edge Adhesives $H \leq \text{PS surface}$ (Including protect film) Edge adhesives seep in $\leq 1/2$ Margin width Length excluding Edge adhesives bubble: bubble Width $\leq 1/2$ Margin width; Length $\leq 5.0\text{mm}$ . $n \leq 5$	MI	Visual / Ruler	Zone B
11	Protect film	Surface scratch but not effect protect function, Allowed		Visual Inspection	
12	Silicon glue	Thickness $\leq \text{PS surface}$ (With protect film): Full cover the IC; Shape: The width on the FPC $\leq 0.5\text{mm}$ (Front) The width on the FPC $\leq 1.0\text{mm}$ (Back) smooth surface, No obvious raised.	MI	Visual Inspection	
13	Warp degree (TFT substrate)	 $t \leq 1.0\text{mm}$	MI	Ruler	
14	Color difference in COM area (Silver point area)	Allowed		Visual Inspection	

DATE NOV.06.2020	Version	1.0	TECHNICAL SPECIFICATION
LCM	YES	YMS152152-0150BABMFGN-R	Page 36 of 37

## 16.Packaging

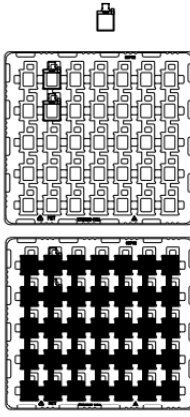
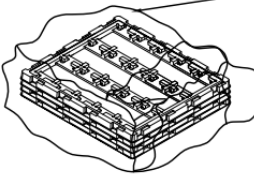
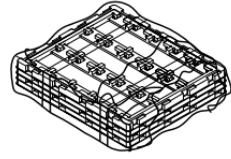
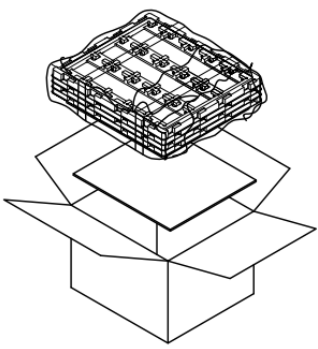
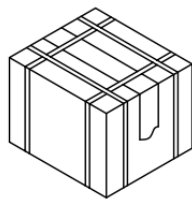
<i>CUSTOMER'S APPROVED:</i>	<i>DATE: 2020.11.11</i>	<i>PAGE: 1/1</i>
<p>PRODUCT PART NO.:YMS152152-0150&amp;YMS152152-0154</p> <p>PACKING TYPE: BY PET TRAY(TPET152152-0154A)</p> <p>PACKLING ORDER:</p> <div style="display: flex; justify-content: space-around;"> <div style="width: 30%;"> <p>1) Putting 35 pcs Modules on each PET tray.And cover a dedicated EPE film.</p>  </div> <div style="width: 30%;"> <p>2) Putting 12 pcs PET trays together with 1 empty tray on the top of PET tray. Insert in the ESD bag, add desiccant in the ESD bag.</p>  </div> <div style="width: 30%;"> <p>3) the tray together with adhesive tape</p>  </div> </div> <div style="display: flex; justify-content: space-around; margin-top: 20px;"> <div style="width: 45%;"> <p>4) Putting into one outcarton</p>  </div> <div style="width: 45%;"> <p>5) Packing finished</p>  </div> </div> <p style="text-align: center; margin-top: 20px;">Note:35 pcs in a tray, 12 trays in a inner carton, 1 inner cartons in a out carton, so 35x12x1=420pcs/Outcarton</p> <p style="text-align: center;">Dimension (Out carton ): 394*344*255mm</p>		
<p>NO. <i>YMS152152-0150&amp;YMS152152-0154 Ver.1</i>    Drw:    Chk:    Apv:</p> <p style="font-weight: bold; font-size: 1.2em;">Yes Optoelectronics Co.,Ltd</p>		

DATE NOV.06.2020	<b>Version</b>	<b>1.0</b>	TECHNICAL SPECIFICATION
<b>LCM</b>	<b>YES</b>	YMS152152-0150BABMFGN-R	Page 37 of 37