

YES OPTOELECTRONICS CO.,LTD

SPECIFICATIONS

Product NO: YMS960680-1330AAAMFGN

DATE: JUL.17.2019

| | |
|-------------|-------------|
| Prepared by | Approved by |
| 王惠颖 | 牛红丽 |



CUSTOMER'S APPROVAL

APPROVED BY: _____ DATE: _____

YES OPTOELECTRONICS CO.,LTD

DD: No.288Yueling Road Anshan,Liaoning,CHINA

TEL: 86-412-5211859 FAX: 86-412-5211729 P.C.:114045

E-mail : yes@yes-lcd.com, yeslcd@globalsources.com

Web: <http://www.yes-lcd.com>

| | | | |
|------------------|---------|-----------------------|-------------------------|
| DATE JUL.17.2019 | Version | 1.0 | TECHNICAL SPECIFICATION |
| LCM | YES | YMS960680-1330AAAMFGN | Page 1 of 25 |

REVISION HISTORY

| Rev | Date | Item | Page | Remark |
|-----|-------------|--------------|------|--------|
| 1.0 | JUL.17.2019 | New Creation | ALL | |

| | | | |
|------------------|----------------|-----------------------|-------------------------|
| DATE JUL.17.2019 | Version | 1.0 | TECHNICAL SPECIFICATION |
| LCM | YES | YMS960680-1330AAAMFGN | Page 2 of 25 |

LIST

| | |
|--|---------|
| 1. Over View----- | (4) |
| 2. Features----- | (4) |
| 3. Mechanical Specifications----- | (4) |
| 4. Mechanical Drawing of EPD module----- | (5) |
| 5. Input /Output Pin Assignment----- | (6-7) |
| 6. Electrical Characteristics----- | (7) |
| 6.1 Absolute Maximum Rating----- | (7) |
| 6.2 Panel DC Characteristics----- | (8) |
| 6.3 Panel DC Characteristics(Driver IC Internal Regulators)----- | (9) |
| 6.4 Panel AC Characteristics----- | (9) |
| 6.4.1 MCU Interface Selection ----- | (9) |
| 6.4.2 MCU Serial Interface(4-wire SPI) ----- | (9-10) |
| 6.4.3 MCU Serial Interface(3-wire SPI) ----- | (11) |
| 6.4.4 Interface Timing----- | (12) |
| 7. Command Table ----- | (13-16) |
| 8. Optical Specifications ----- | (17) |
| 9. Handling, Safety and Environment Requirements ----- | (17) |
| 10. Reliability test----- | (18) |
| 11. Block Diagram----- | (19) |
| 12. Typical Application Circuit with SPI Interface ----- | (19) |
| 13. Typical Operating Sequence ----- | (20) |
| 13.1 Normal Operation Flow ----- | (20) |
| 13.2 Normal Operation Reference Program Code----- | (21) |
| 14. Part Number Definition----- | (21) |
| 15. Inspection condition----- | (22) |
| 15.1 Environment----- | (22) |
| 15.2 Illuminance----- | (22) |
| 15.3 Inspect method----- | (22) |
| 15.4 Display area----- | (22) |
| 15.5 Inspection standard----- | (23) |
| 15.5.1 Electric inspection standard----- | (23) |
| 15.5.2 Appearance inspection standard----- | (24-25) |
| 16.Packaging----- | (25) |

| | | | |
|------------------|----------------|-----------------------|-------------------------|
| DATE JUL.17.2019 | Version | 1.0 | TECHNICAL SPECIFICATION |
| LCM | YES | YMS960680-1330AAAMFGN | Page 3 of 25 |

1. Over View

YMS960680-1330AAAMFGN is an Active Matrix Electrophoretic Display (AM EPD), with interface and a reference system design. The display is capable to display image at 1-bit white, black full display capabilities. The 13.3inch active area contains 960×680 pixels. The module is a TFT-array driving electrophoresis display, with integrated circuits including gate driver, source driver, MCU interface, timing controller, oscillator, DC-DC, SRAM, LUT, VCOM. Module can be used in portable electronic devices, such as Electronic Shelf Label (ESL) System.

2. Features

- 960×680 pixels display
- High contrast High reflectance
- Ultra wide viewing angle Ultra low power consumption
- Pure reflective mode
- Bi-stable display
- Commercial temperature range
- Landscape portrait modes
- Hard-coat antiglare display surface
- Ultra Low current deep sleep mode
- On chip display RAM
- Waveform can stored in On-chip OTP or written by MCU
- Serial peripheral interface available
- On-chip oscillator
- On-chip booster and regulator control for generating VCOM, Gate and Source driving voltage
- I²C signal master interface to read external temperature sensor
- Built-in temperature sensor

3. Mechanical Specifications

| Parameter | Specifications | Unit | Remark |
|---------------------|-------------------------------|-------|--------|
| Screen Size | 13.3 | Inch | |
| Display Resolution | 960(H)×680(V) | Pixel | Dpi:88 |
| Active Area | 275.52×195.16 | mm | |
| Pixel Pitch | 0.287×0.287 | mm | |
| Pixel Configuration | Rectangle | | |
| Outline Dimension | 286.32(H)×212.26 (V) ×1.20(D) | mm | |
| Weight | 106.7±0.5 | g | |

| | | | |
|------------------|---------|-----------------------|-------------------------|
| DATE JUL.17.2019 | Version | 1.0 | TECHNICAL SPECIFICATION |
| LCM | YES | YMS960680-1330AAAMFGN | Page 4 of 25 |

4. Mechanical Drawing of EPD Module

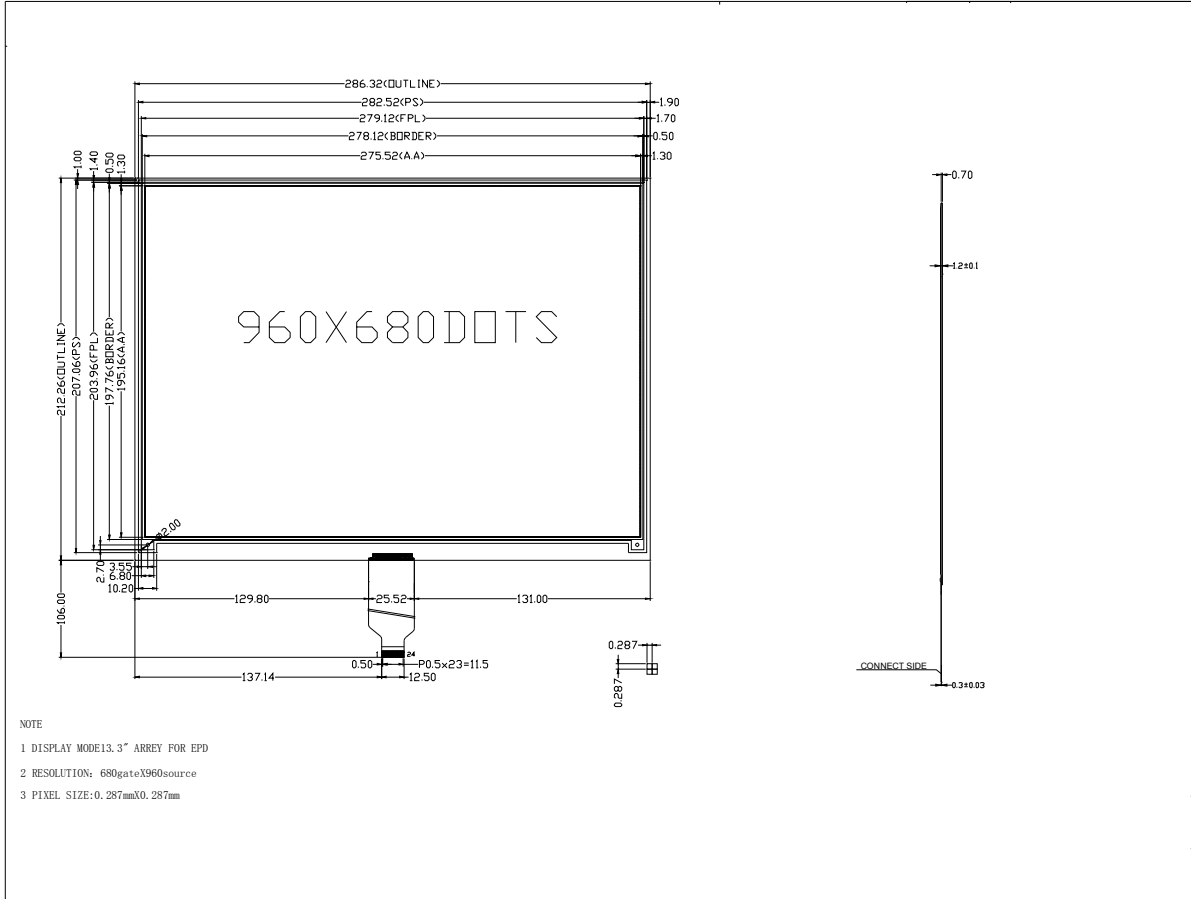

5. Input /Output Pin Assignment

| No. | Name | I/O | Description | Remark |
|-----|-------|-----|--|-----------|
| 1 | NC | | Do not connect with other NC pins | Keep Open |
| 2 | GDR | O | N-Channel MOSFET Gate Drive Control | |
| 3 | RESE | I | Current Sense Input for the Control Loop | |
| 4 | NC | NC | Do not connect with other NC pins | Keep Open |
| 5 | VSH | C | Positive Source driving voltage | |
| 6 | TSCL | O | I2C Interface to digital temperature sensor Clock pin | |
| 7 | TSDA | I/O | I2C Interface to digital temperature sensor Data pin | |
| 8 | BS1 | I | Bus Interface selection pin | Note 5-5 |
| 9 | BUSY | O | Busy state output pin | Note 5-4 |
| 10 | RES# | I | Reset signal input. Active Low. | Note 5-3 |
| 11 | D/C# | I | Data /Command control pin | Note 5-2 |
| 12 | CS# | I | Chip select input pin | Note 5-1 |
| 13 | SCL | I | Serial Clock pin (SPI) | |
| 14 | SDA | I | Serial Data pin (SPI) | |
| 15 | VDDIO | P | Power Supply for interface logic pins It should be connected with VCI | |
| 16 | VCI | P | Power Supply for the chip | |
| 17 | VSS | P | Ground | |
| 18 | VDD | C | Core logic power pin VDD can be regulated internally from VCI. A capacitor should be connected between VDD and VSS | |
| 19 | VPP | P | FOR TEST | Keep Open |
| 20 | VSH1 | C | Positive Source driving voltage | |
| 21 | VGH | C | Power Supply pin for Positive Gate driving voltage and VSH1 | |
| 22 | VSL | C | Negative Source driving voltage | |
| 23 | VGL | C | Power Supply pin for Negative Gate driving voltage VCOM and VSL | |
| 24 | VCOM | C | VCOM driving voltage | |

DATE JUL.17.2019

Version

1.0

TECHNICAL SPECIFICATION

LCM

YES

YMS960680-1330AAAMFGN

Page 6 of 25

I = Input Pin, O =Output Pin, /O = Bi-directional Pin (Input/output), P = Power Pin, C = Capacitor Pin

Note 5-1: This pin (CS#) is the chip select input connecting to the MCU. The chip is enabled for MCU communication only when CS# is pulled LOW.

Note 5-2: This pin is (D/C#) Data/Command control pin connecting to the MCU in 4-wire SPI mode. When the pin is pulled HIGH, the data at SDA will be interpreted as data. When the pin is pulled LOW, the data at SDA will be interpreted as command.

Note 5-3: This pin (RES#) is reset signal input. The Reset is active low.

Note 5-4: This pin is Busy state output pin. When Busy is High, the operation of chip should not be interrupted, command should not be sent. The chip would put Busy pin High when –Outputting display waveform -Communicating with digital temperature sensor

Note 5-5: Bus interface selection pin

| BS1 State | MCU Interface |
|-----------|--|
| L | 4-lines serial peripheral interface(SPI) - 8 bits SPI |
| H | 3- lines serial peripheral interface(SPI) - 9 bits SPI |

6. Electrical Characteristics

6.1 Absolute Maximum Rating

| Parameter | Symbol | Rating | Unit |
|--------------------------|--------|------------------|------|
| Logic supply voltage | VCI | -0.5 to +4.0 | V |
| Logic Input voltage | VIN | -0.5 to VCI +0.5 | V |
| Logic Output voltage | VOUT | -0.5 to VCI +0.5 | V |
| Operating Temp range | TOPR | 0 to +50 | °C. |
| Storage Temp range | TSTG | -25 to+70 | °C. |
| Optimal Storage Temp | TSTGo | 23±2 | °C. |
| Optimal Storage Humidity | HSTGo | 55±10% | RH |
| Logic supply voltage | VCI | -0.5 to +4.0 | V |

Note:

1.Maximum ratings are those values beyond which damages to the device may occur. Functional operation should be restricted to the limits in the Panel DC Characteristics tables.

| | | | |
|------------------|----------------|-----------------------|-------------------------|
| DATE JUL.17.2019 | Version | 1.0 | TECHNICAL SPECIFICATION |
| LCM | YES | YMS960680-1330AAAMFGN | Page 7 of 25 |

6.2 Panel DC Characteristics

The following specifications apply for: VSS=0V, VCI=3.0V, TOPR =23°C.

| Parameter | Symbol | Condition | Applicable pin | Min. | Typ. | Max. | Unit |
|---------------------------|-----------------------|---|-----------------|---------------------|-------|---------------------|------|
| Single ground | V _{SS} | - | | - | 0 | - | V |
| Logic supply voltage | V _{CI} | - | V _{CI} | 2.2 | 3.0 | 3.7 | V |
| Core logic voltage | V _{DD} | | V _{DD} | 1.7 | 1.8 | 1.9 | V |
| High level input voltage | V _{IH} | - | - | 0.8 V _{CI} | - | - | V |
| Low level input voltage | V _{IL} | - | - | - | - | 0.2 V _{CI} | V |
| High level output voltage | V _{OH} | I _{OH} = -100uA | - | 0.9 V _{CI} | - | - | V |
| Low level output voltage | V _{OL} | I _{OL} = 100uA | - | - | - | 0.1 V _{CI} | V |
| Typical power | P _{TYP} | V _{CI} =3.0V | - | - | 60 | - | mW |
| Deep sleep mode | P _{STPY} | V _{CI} =3.0V | - | - | 0.003 | - | mW |
| Typical operating current | I _{opr_VCI} | V _{CI} =3.0V | - | - | 20 | - | mA |
| Image update time | - | 23 °C | - | - | 6 | - | sec |
| Sleep mode current | I _{slp_VCI} | DC/DC off No clock No input load Ram data retain | - | - | 20 | - | uA |
| Deep sleep mode current | I _{dslp_VCI} | DC/DC off No clock No input load Ram data not retain | - | - | 3 | 5 | uA |

Notes:

- The typical power is measured with following transition from horizontal 2 scale pattern to vertical 2 scale pattern.

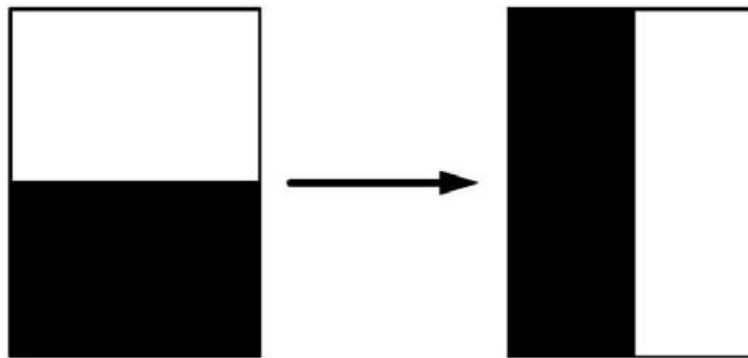

- The deep sleep power is the consumed power when the panel controller is in deep sleep mode.
- The listed electrical/optical characteristics are only guaranteed under the controller & waveform provided by YES

| | | | |
|------------------|----------------|-----------------------|-------------------------|
| DATE JUL.17.2019 | Version | 1.0 | TECHNICAL SPECIFICATION |
| LCM | YES | YMS960680-1330AAAMFGN | Page 8 of 25 |

6.3 Panel DC Characteristics(Driver IC Internal Regulators)

The following specifications apply for: VSS=0V, VCI=3.0V, TOPR =23°C.

| Parameter | Symbol | Condition | Applicable pin | Min. | Typ. | Max. | Unit |
|--------------------------------|-----------------|-----------|----------------------------------|-------|------|-------|------|
| VCOM output voltage | VCOM | - | VCOM | - | TBD | - | V |
| Positive Source output voltage | V _{SH} | - | S ₀ ~S ₁₂₇ | +14.5 | +15 | +15.5 | V |
| Negative Source output voltage | V _{SL} | - | S ₀ ~S ₁₂₇ | -15.5 | -15 | -14.5 | V |
| Positive gate output voltage | V _{gh} | - | G ₀ ~G ₂₉₅ | +21 | +22 | +23 | V |
| Negative gate output voltage | V _{gl} | - | G ₀ ~G ₂₉₅ | -21 | -20 | -19 | V |

6.4 Panel AC Characteristics

6.4.1 MCU Interface Selection

The pin assignment at different interface mode is summarized in Table 6-4-1. Different MCU mode can be set by hardware selection on BS1 pins. The display panel only supports 4-wire SPI or 3-wire SPI interface mode.

| Pin Name | Data/Command Interface | | Control Signal | | |
|------------------|------------------------|-----|----------------|------|------|
| Bus interface | SDA | SCL | CS# | D/C# | RES# |
| BS1=L 4-wire SPI | SDA | SCL | CS# | D/C# | RES# |
| BS1=H 3-wire SPI | SDA | SCL | CS# | L | RES# |

6.4.2 MCU Serial Interface (4-wire SPI)

The serial interface consists of serial clock SCL, serial data SDA, D/C#, CS#. This interface supports Write mode and Read mode.

| Function | CS# | D/C# | SCL |
|---------------|-----|------|-----|
| Write command | L | L | ↑ |
| Write data | L | H | ↑ |

Note: ↑ stands for rising edge of signal

In the write mode SDA is shifted into an 8-bit shift register on every rising edge of SCL in the order of D7, D6, ... D0. The level of D/C# should be kept over the whole byte. The data byte in the shift register is written to the Graphic Display Data RAM /Data Byte register or command Byte register according to D/C# pin.

| | | | |
|------------------|----------------|-----------------------|-------------------------|
| DATE JUL.17.2019 | Version | 1.0 | TECHNICAL SPECIFICATION |
| LCM | YES | YMS960680-1330AAAMFGN | Page 9 of 25 |

Figure 6-1: Write procedure in 4-wire SPI mode

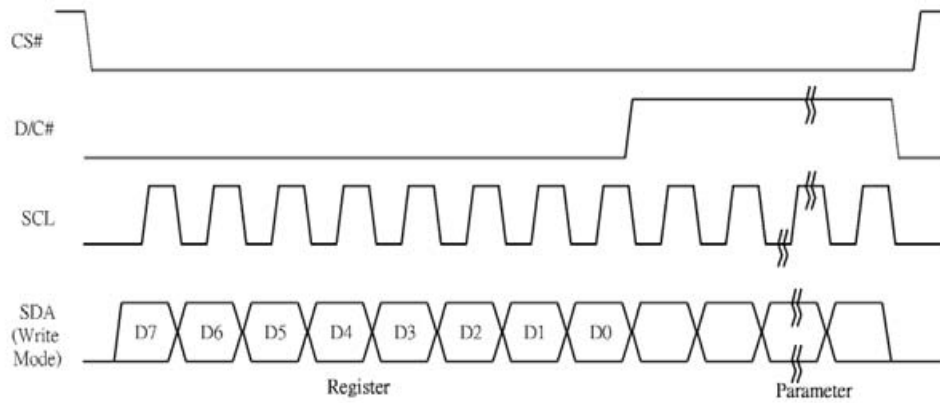

In the Read mode:

1. After driving CS# to low, MCU need to define the register to be read.
2. SDA is shifted into an 8-bit shift register on every rising edge of SCL in the order of D7, D6, ... D0 with D/C# keep low.
3. After SCL change to low for the last bit of register, D/C# need to drive to high.
4. SDA is shifted out an 8-bit data on every falling edge of SCL in the order of D7, D6, ... D0.
5. Depending on register type, more than 1 byte can be read out. After all byte are read, CS# need to drive to high to stop the read operation.

Figure 6-2: Read procedure in 4-wire SPI mode

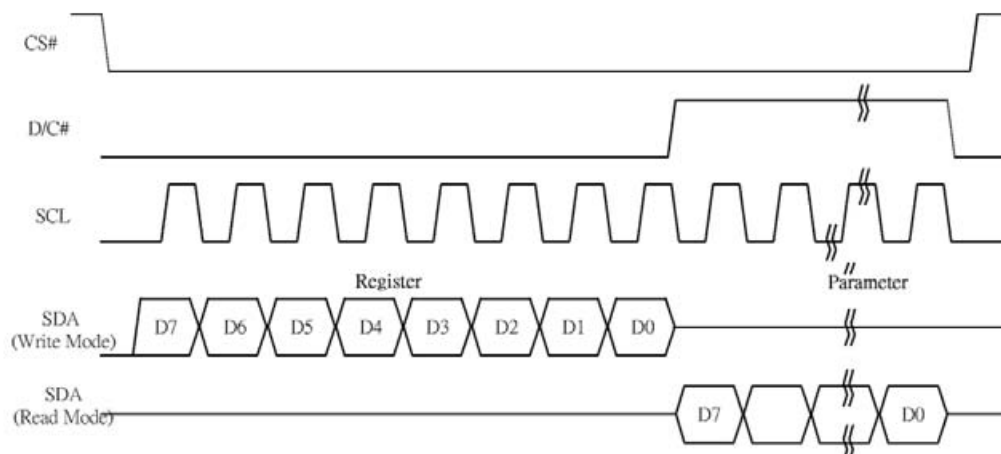

| | | | |
|------------------|----------------|-----------------------|-------------------------|
| DATE JUL.17.2019 | Version | 1.0 | TECHNICAL SPECIFICATION |
| LCM | YES | YMS960680-1330AAAMFGN | Page 10 of 25 |

6.4.3 MCU Serial Interface (3-wire SPI)

The 3-wire serial interface consists of serial clock SCL, serial data SDA and CS#. This interface also supports Write mode and Read mode.

The operation is similar to 4-wire serial interface while D/C# pin is not used. There are altogether 9-bits will be shifted into the shift register on every ninth clock in sequence: D/C# bit, D7 to D0 bit. The D/C# bit (first bit of the sequential data) will determine the following data byte in the shift register is written to the Display Data RAM (D/C# bit = 1) or the command register (D/C# bit = 0).

| Function | CS# | D/C# | SCL |
|---------------|-----|------|-----|
| Write command | L | Tie | ↑ |
| Write data | L | Tie | ↑ |

Note: ↑ stands for rising edge of signal

Figure 6-3: Write procedure in 3-wire SPI mode

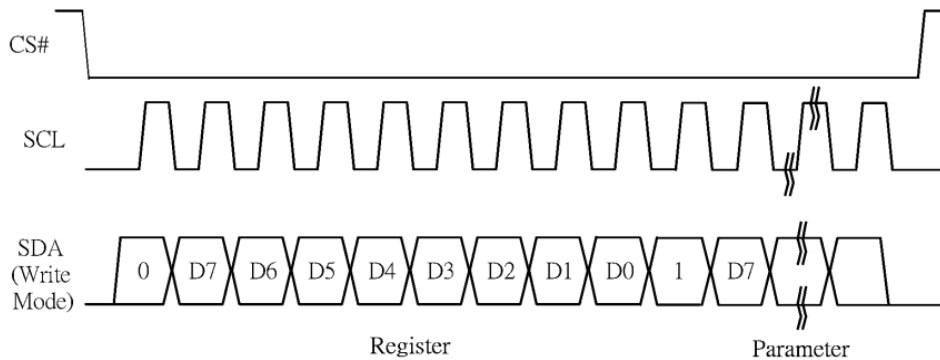

In the Read mode:

1. After driving CS# to low, MCU need to define the register to be read.
2. D/C=0 is shifted thru SDA with one rising edge of SCL
3. SDA is shifted into an 8-bit shift register on every rising edge of SCL in the order of D7, D6, ... D0.
4. D/C=1 is shifted thru SDA with one rising edge of SCL
5. SDA is shifted out an 8-bit data on every falling edge of SCL in the order of D7, D6, ... D0.
6. Depending on register type, more than 1 byte can be read out. After all byte are read, CS# need to drive to high to stop the read operation.

Figure 6-4: Read procedure in 3-wire SPI mode

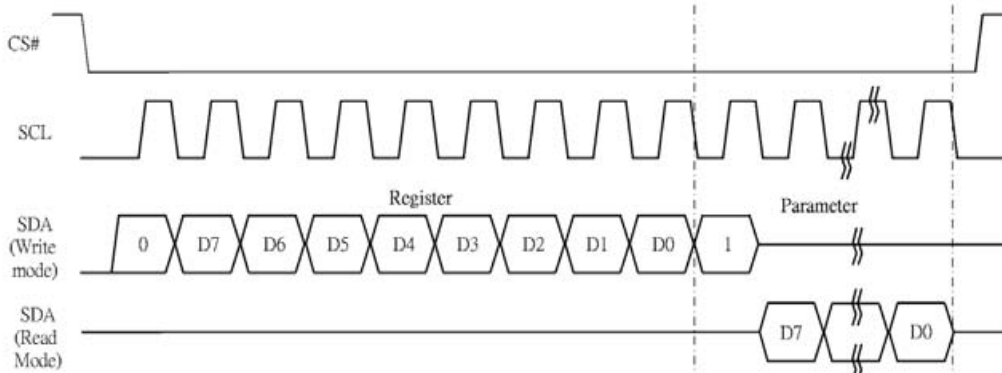

| | | | |
|------------------|---------|-----------------------|-------------------------|
| DATE JUL.17.2019 | Version | 1.0 | TECHNICAL SPECIFICATION |
| LCM | YES | YMS960680-1330AAAMFGN | Page 11 of 25 |

6.4.4 Interface Timing

The following specifications apply for: VSS=0V, VCI=3.0V, TOPR =23°C.

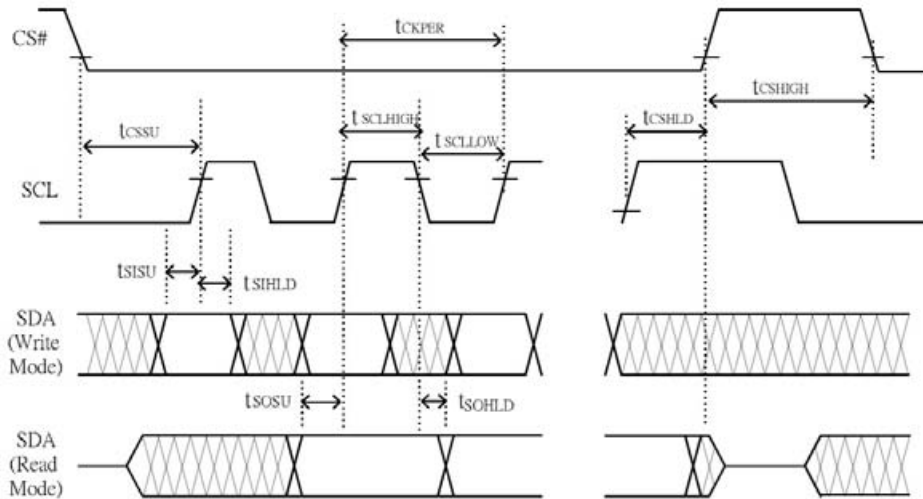

Changed Diagram

Serial Interface Timing Characteristics

(VCI - VSS = 2.2V to 3.7V, TOPR = 23°C, CL=20pF)

Write mode

| Symbol | Parameter | Min | Typ. | Max | Unit |
|----------|--|-----|------|-----|------|
| fSCL | SCL frequency (Write Mode) | | | 20 | MHz |
| tCSSU | Time CS# has to be low before the first rising edge of SCLK | 20 | | | ns |
| tCSHLD | Time CS# has to remain low after the last falling edge of SCLK | 20 | | | ns |
| tCSHIGH | Time CS# has to remain high between two transfers | 100 | | | ns |
| tSCLHIGH | Part of the clock period where SCL has to remain high | 25 | | | ns |
| tSCLLOW | Part of the clock period where SCL has to remain low | 25 | | | ns |
| tSISU | Time SI (SDA Write Mode) has to be stable before the next rising edge of SCL | 10 | | | ns |
| tSIHLD | Time SI (SDA Write Mode) has to remain stable after the rising edge of SCL | 40 | | | ns |

Read mode

| Symbol | Parameter | Min | Typ. | Max | Unit |
|----------|--|-----|------|-----|------|
| fSCL | SCL frequency (Read Mode) | | | 2.5 | MHz |
| tCSSU | Time CS# has to be low before the first rising edge of SCLK | 100 | | | ns |
| tCSHLD | Time CS# has to remain low after the last falling edge of SCLK | 50 | | | ns |
| tCSHIGH | Time CS# has to remain high between two transfers | 250 | | | ns |
| tSCLHIGH | Part of the clock period where SCL has to remain high | 180 | | | ns |
| tSCLLOW | Part of the clock period where SCL has to remain low | 180 | | | ns |
| tSOSU | Time SO(SDA Read Mode) will be stable before the next rising edge of SCL | | 50 | | ns |
| tSOHLD | Time SO (SDA Read Mode) will remain stable after the rising edge of SCL | | 70 | | ns |

| | | | |
|------------------|----------------|-----------------------|-------------------------|
| DATE JUL.17.2019 | Version | 1.0 | TECHNICAL SPECIFICATION |
| LCM | YES | YMS960680-1330AAAMFGN | Page 12 of 25 |

7. Command Table

| R/W# | D/C# | Hex | D7 | D6 | D5 | D4 | D3 | D2 | D1 | D0 | Command | Description | | | | | | |
|--|-----------------------|-----|----|----|----|----|----|----------------|----------------|----------------|--------------------------------|---|--------|-------------|----|-------------------|----|-----------------------|
| 0 | 0 | 01 | 0 | 0 | 0 | 0 | 0 | 0 | 0 | 1 | Driver Output control | Gate setting Set A[9:0]=2A7h[POR] ,680MUX Set B[2:0]=000[POR] | | | | | | |
| 0 | 1 | | A7 | A6 | A5 | A4 | A3 | A2 | A1 | A0 | | | | | | | | |
| 0 | 1 | | 0 | 0 | 0 | 0 | 0 | 0 | A9 | A8 | | | | | | | | |
| 0 | 1 | | 0 | 0 | 0 | 0 | 0 | B2 | B1 | B0 | | | | | | | | |
| 0 | 0 | 03 | 0 | 0 | 0 | 0 | 0 | 0 | 1 | 1 | Gate Driving voltage control | SetGate Driving voltage A[4:0]=17h[POR],VGH at 20V[POR] VGH setting from 12V to 20V | | | | | | |
| 0 | 1 | | 0 | 0 | 0 | A4 | A3 | A2 | A1 | A0 | | | | | | | | |
| 0 | 0 | 04 | 0 | 0 | 0 | 0 | 0 | 1 | 0 | 0 | Source Driving voltage control | SetSource Driving voltage A[7:0]= 41h[POR],VSH1 at 15V B[7:0]=A8h[POR],VSH2 at 5.0V C[7:0]= 32h[POR], VSL at -15V | | | | | | |
| 0 | 1 | | A7 | A6 | A5 | A4 | A3 | A2 | A1 | A0 | | | | | | | | |
| 0 | 1 | | B7 | B6 | B5 | B4 | B3 | B2 | B1 | B0 | | | | | | | | |
| 0 | 1 | | C7 | C6 | C5 | C4 | C3 | C2 | C1 | C0 | | | | | | | | |
| 0 | 0 | 10 | 0 | 0 | 0 | 1 | 0 | 0 | 0 | 0 | Deep Sleep mode | Deep Sleep mode Control | | | | | | |
| 0 | 1 | | 0 | 0 | 0 | 0 | 0 | 0 | A ₁ | A ₀ | | <table border="1"> <thead> <tr> <th>A[1:0]</th> <th>Description</th> </tr> </thead> <tbody> <tr> <td>00</td> <td>Normal Mode [POR]</td> </tr> <tr> <td>11</td> <td>Enter Deep Sleep Mode</td> </tr> </tbody> </table> | A[1:0] | Description | 00 | Normal Mode [POR] | 11 | Enter Deep Sleep Mode |
| A[1:0] | Description | | | | | | | | | | | | | | | | | |
| 00 | Normal Mode [POR] | | | | | | | | | | | | | | | | | |
| 11 | Enter Deep Sleep Mode | | | | | | | | | | | | | | | | | |
| After this command initiated, the chip will enter Deep Sleep Mode, BUSY pad will keep output high. | | | | | | | | | | | | | | | | | | |
| 0 | 0 | 11 | 0 | 0 | 0 | 1 | 0 | 0 | 0 | 1 | Data Entry mode setting | Define data entry sequence A [1:0] = ID[1:0]Address automatic increment / decrement setting The setting of incrementing or decrementing of the address counter can be made independently in each upper and lower bit of the address. 00 -Y decrement, X decrement, 01 -Y decrement, X increment, 10 -Y increment, X decrement, 11 -Y increment, X increment [POR] A[2] = AM Set the direction in which the address counter is updated automatically after data are written to the RAM. AM= 0, the address counter is updated in the X direction. [POR] AM = 1, the address counter is updated in the Y direction. | | | | | | |
| 0 | 1 | | 0 | 0 | 0 | 0 | 0 | A ₂ | A ₁ | A ₀ | | | | | | | | |
| 0 | 0 | 12 | 0 | 0 | 0 | 1 | 0 | 0 | 1 | 0 | SWRESET | It resets the commands and parameters to their S/W Reset default values except R10h-Deep Sleep Mode During operation ,BUSY pad will output high. Note: RAM are unaffected by this command. | | | | | | |

| | | | |
|------------------|---------|-----------------------|-------------------------|
| DATE JUL.17.2019 | Version | 1.0 | TECHNICAL SPECIFICATION |
| LCM | YES | YMS960680-1330AAAMFGN | Page 13 of 25 |

| | | | | | | | | | | | | |
|---|---|----|-----|-----|----|----|----|----|----|----|--|---|
| 0 | 0 | 18 | 0 | 0 | 0 | 1 | 1 | 0 | 0 | 0 | Temperature Sensor Control | Temperature Sensor Selection A[7:0] = 48h [POR], external temperature sensor A[7:0] = 80h Internal temperature sensor |
| 0 | 1 | | A7 | A6 | A5 | A4 | A3 | A2 | A1 | A0 | | |
| 0 | 0 | 1A | 0 | 0 | 0 | 1 | 1 | 0 | 1 | 0 | Temperature Sensor Control (Write to temperature register) | Write to temperature register. A[11:0]=7FFh[POR] |
| 0 | 1 | | A11 | A10 | A9 | A8 | A7 | A6 | A5 | A4 | | |
| 0 | 1 | | A3 | A2 | A1 | A0 | 0 | 0 | 0 | 0 | | |
| 0 | 0 | 20 | 0 | 0 | 1 | 0 | 0 | 0 | 0 | 0 | Master Activation | Activate Display Update Sequence The Display Update Sequence Option is located at R22h User should not interrupt this operation to avoid corruption of panel images. |
| 0 | 0 | 21 | 0 | 0 | 1 | 0 | 0 | 0 | 0 | 1 | Display Update Control 1 | RAM content option for Display Update A[7:0]=00h[POR] A[7:4] Red RAM option 0000 Normal 0100 Bypass RAM content as 0 1000 Inverse RAM content A[3:0] BW RAM option 0000 Normal 0100 Bypass RAM content as 0 1000 Inverse RAM content |
| 0 | 1 | | A7 | A6 | A5 | A4 | A3 | A2 | A1 | A0 | | |
| 0 | 0 | 22 | 0 | 0 | 1 | 0 | 0 | 0 | 1 | 0 | Display Update Control 2 | Display Update Sequence Option: Enable the stage for Master Activation Setting for LUT from MCU Enable Clock Signal, Then Enable Analog Then PATTERN DISPLAY C7 Then Disable Analog Then Disable OSC Setting for LUT from OTP according to external Temperature Sensor operation Then Enable Analog Then Load LUT 90 Enable Analog Then PATTERN DISPLAY Then Disable Analog Then Disable OSC 47 |
| | 1 | | A7 | A6 | A5 | A4 | A3 | A2 | A1 | A0 | | |
| 0 | 0 | 24 | 0 | 0 | 1 | 0 | 0 | 1 | 0 | 0 | Write RAM (BW) | After this command, data entries will be written into the 1RAM until another command is written. Address pointers will advance accordingly. For Write pixel: Content of write RAM(BW)=1 For Black pixel: Content of write RAM(BW)=0 |

| | | | |
|------------------|---------|-----------------------|-------------------------|
| DATE JUL.17.2019 | Version | 1.0 | TECHNICAL SPECIFICATION |
| LCM | YES | YMS960680-1330AAAMFGN | Page 14 of 25 |

| | | | | | | | | | | | | |
|---|---|----|----|----|----|----|----|----|----|----|---------------------|--|
| 0 | 0 | 26 | 0 | 0 | 1 | 0 | 0 | 1 | 1 | 0 | Write RAM (RED) | After this command, data entries will be written into the 2 RAM until another command is written. Address pointers will advance accordingly. For RED pixel: Content of write RAM(RED)=1 For White/Black pixel: Content of write RAM(RED)=0 |
| 0 | 0 | 2C | 0 | 0 | 1 | 0 | 1 | 1 | 0 | 0 | Write VCOM register | Set A[7:0]=50h |
| 0 | 1 | | A7 | A6 | A5 | A4 | A3 | A2 | A1 | A0 | OTP Register Read | Read Register stored in OTP: 1. A[7:0]~ B[7:0]: VCOM Information 2. C[7:0]~G[7:0]:Display mode 3. H[7:0]~K[7:0]: Waveform Version [4bytes] |
| 0 | 0 | 2D | 0 | 0 | 1 | 0 | 1 | 1 | 0 | 1 | | |
| 1 | 1 | | A7 | A6 | A5 | A4 | A3 | A2 | A1 | A0 | | |
| 1 | 1 | | B7 | B6 | B5 | B4 | B3 | B2 | B1 | B0 | | |
| 1 | 1 | | C7 | C6 | C5 | C4 | C3 | C2 | C1 | C0 | | |
| 1 | 1 | | D7 | D6 | D5 | D4 | D3 | D2 | D1 | D0 | | |
| 1 | 1 | | E7 | E6 | E5 | E4 | E3 | E2 | E1 | E0 | | |
| 1 | 1 | | F7 | F6 | F5 | F4 | F3 | F2 | F1 | F0 | | |
| 1 | 1 | | G7 | G6 | G5 | G4 | G3 | G2 | G1 | G0 | | |
| 1 | 1 | | H7 | H6 | H5 | H4 | H3 | H2 | H1 | H0 | | |
| 1 | 1 | | I7 | I6 | I5 | I4 | I3 | I2 | I1 | I0 | | |
| 1 | 1 | | J7 | J6 | J5 | J4 | J3 | J2 | J1 | J0 | | |
| 1 | 1 | | K7 | K6 | K5 | K4 | K3 | K2 | K1 | K0 | | |
| 0 | 0 | 2F | 0 | 0 | 1 | 0 | 1 | 1 | 1 | 1 | Status Bit Read | Read IC status Bit [POR 0x21] A[5]: HV Ready Detection flag [POR=1] 0: Ready 1: Not Ready A[4]: VCI Detection flag [POR=0] 0: Normal 1: VCI lower than the Detect level A[3]: [POR=0] A[2]: Busy flag [POR=0] 0: Normal 1: BUSY A[1:0]: Chip ID [POR=01] Remark: A[5] and A[4] status are not valid after RESET, they need to be initiated by command 0x14 and command 0x15 respectively. |
| 1 | 1 | | 0 | 0 | A5 | A4 | 0 | 0 | A1 | A0 | | |
| 0 | 0 | 32 | 0 | 0 | 1 | 1 | 0 | 0 | 1 | 0 | Write LUT register | Write LUT register from MCU interface [105 bytes]. |
| 0 | 1 | | A7 | A6 | A5 | A4 | A3 | A2 | A1 | A0 | | |
| 0 | 1 | | B7 | B6 | B5 | B4 | B3 | B2 | B1 | B0 | | |
| 0 | 1 | | : | : | : | : | : | : | : | : | | |
| 0 | 1 | | : | : | : | : | : | : | : | : | | |
| 0 | 1 | | : | : | : | : | : | : | : | : | | |

| | | | |
|------------------|---------|-----------------------|-------------------------|
| DATE JUL.17.2019 | Version | 1.0 | TECHNICAL SPECIFICATION |
| LCM | YES | YMS960680-1330AAAMFGN | Page 15 of 25 |

| | | | | | | | | | | | | | | | | | | | | | | | | | | | | | | | | | | | | | | | | | | | | | | | | | | | | | | | | | | | | | | | | | | | | | | | | | | | | | | | | | | | | | | | | | | | | | | | | | | | | | | | | | | | | | | | | | | | | | | | | | | | | | | | | | | | | | | | | | | | | | | | | | | | | | | | | | | | | | | | | | | | | | | | | | | | | | | | | | | | | | | | | | | | | | | | | | | | | | | | | | | | | | | | | | | | | | | | | | | | | | | | | | | | | | | | | | | | | | | | | | | | | | | | | | | | | | | | | | | | | | | | | | | | | | | | | | | | | | | | | | | | | | | | | | | | | | | | | | | | | | | | | | | | | | | | | | | | | | | | | | | | | | | | | | | | | | | | | | | | | | | | | | | | | | | | | | | | | | | | | | | | | | | | | | | | | | | | | | | | | | | | | | | | | | | | | | | | | | | | | | | | | | | | | | | | | | | | | | | | | | | | | | | | | |
|---|---|----|----------------|----------------|----------------|----------------|----------------|----------------|----------------|----------------|--|---|-----------------------------------|--------------------------------|--|--|--|--|--|--|--|--|--|--------|---------------|--|--|--|--|--|--|--|--|--|--|--|----|--------------------------------|--|--|--|--|--|--|--|--|--|--|--|----|-----------------------------|--|--|--|--|--|--|--|--|--|--|--|----|------|--|--|--|--|--|--|--|--|--|--|--|---------|-----|--|--|--|--|--|--|--|--|--|--|--|-----------------------------------|--|--|--|--|--|--|--|--|--|--|--|--|--------|-----------|--|--|--|--|--|--|--|--|--|--|--|---------|-----|--|--|--|--|--|--|--|--|--|--|--|----|------|--|--|--|--|--|--|--|--|--|--|--|----|-----|--|--|--|--|--|--|--|--|--|--|--|----|------|--|--|--|--|--|--|--|--|--|--|--|--------------------------------------|--|--|--|--|--|--|--|--|--|--|--|--|--------|----------------|--|--|--|--|--|--|--|--|--|--|--|----------|------|--|--|--|--|--|--|--|--|--|--|--|----|------|--|--|--|--|--|--|--|--|--|--|--|----|------|--|--|--|--|--|--|--|--|--|--|--|----|------|---|---|----|---|---|---|---|---|---|---|---|--|---|---|---|--|----------------|----------------|----------------|----------------|----------------|----------------|----------------|----------------|---|---|--|---|---|---|---|---|---|----------------|----------------|---|---|--|----------------|----------------|----------------|----------------|----------------|----------------|----------------|----------------|---|---|--|---|---|---|---|---|---|----------------|----------------|---|---|----|---|---|---|---|---|---|---|---|--|---|---|---|--|----------------|----------------|----------------|----------------|----------------|----------------|----------------|----------------|---|---|--|---|---|---|---|---|---|----------------|----------------|---|---|--|----------------|----------------|----------------|----------------|----------------|----------------|----------------|----------------|---|---|--|---|---|---|---|---|---|----------------|----------------|---|---|----|---|---|---|---|---|---|---|---|------------------------------|---|---|---|--|----------------|----------------|----------------|----------------|----------------|----------------|----------------|----------------|---|---|--|---|---|---|---|---|---|----------------|----------------|---|---|----|---|---|---|---|---|---|---|---|------------------------------|---|---|---|--|----------------|----------------|----------------|----------------|----------------|----------------|----------------|----------------|---|---|--|---|---|---|---|---|---|----------------|----------------|---|---|--|----------------|----------------|----------------|----------------|----------------|----------------|----------------|----------------|
| 0 | 0 | 3A | 0 | 0 | 1 | 1 | 1 | 0 | 1 | 0 | Reserved | Reserved | | | | | | | | | | | | | | | | | | | | | | | | | | | | | | | | | | | | | | | | | | | | | | | | | | | | | | | | | | | | | | | | | | | | | | | | | | | | | | | | | | | | | | | | | | | | | | | | | | | | | | | | | | | | | | | | | | | | | | | | | | | | | | | | | | | | | | | | | | | | | | | | | | | | | | | | | | | | | | | | | | | | | | | | | | | | | | | | | | | | | | | | | | | | | | | | | | | | | | | | | | | | | | | | | | | | | | | | | | | | | | | | | | | | | | | | | | | | | | | | | | | | | | | | | | | | | | | | | | | | | | | | | | | | | | | | | | | | | | | | | | | | | | | | | | | | | | | | | | | | | | | | | | | | | | | | | | | | | | | | | | | | | | | | | | | | | | | | | | | | | | | | | | | | | | | | | | | | | | | | | | | | | | | | | | | | | | | | | | | | | | | | | | | | | | | | | | | | | | | | | | | | | | | | | | | | | | | | |
| 0 | 0 | 3B | 0 | 0 | 1 | 1 | 1 | 0 | 1 | 1 | Reserved | Reserved | | | | | | | | | | | | | | | | | | | | | | | | | | | | | | | | | | | | | | | | | | | | | | | | | | | | | | | | | | | | | | | | | | | | | | | | | | | | | | | | | | | | | | | | | | | | | | | | | | | | | | | | | | | | | | | | | | | | | | | | | | | | | | | | | | | | | | | | | | | | | | | | | | | | | | | | | | | | | | | | | | | | | | | | | | | | | | | | | | | | | | | | | | | | | | | | | | | | | | | | | | | | | | | | | | | | | | | | | | | | | | | | | | | | | | | | | | | | | | | | | | | | | | | | | | | | | | | | | | | | | | | | | | | | | | | | | | | | | | | | | | | | | | | | | | | | | | | | | | | | | | | | | | | | | | | | | | | | | | | | | | | | | | | | | | | | | | | | | | | | | | | | | | | | | | | | | | | | | | | | | | | | | | | | | | | | | | | | | | | | | | | | | | | | | | | | | | | | | | | | | | | | | | | | | | | | | | | | |
| 0 | 0 | 3C | 0 | 0 | 1 | 1 | 1 | 1 | 0 | 0 | Border Waveform Control | Select border waveform for VBD A [7:0]=C0h[POR],set VBD as HIZ A [7:6] Select VBD option | | | | | | | | | | | | | | | | | | | | | | | | | | | | | | | | | | | | | | | | | | | | | | | | | | | | | | | | | | | | | | | | | | | | | | | | | | | | | | | | | | | | | | | | | | | | | | | | | | | | | | | | | | | | | | | | | | | | | | | | | | | | | | | | | | | | | | | | | | | | | | | | | | | | | | | | | | | | | | | | | | | | | | | | | | | | | | | | | | | | | | | | | | | | | | | | | | | | | | | | | | | | | | | | | | | | | | | | | | | | | | | | | | | | | | | | | | | | | | | | | | | | | | | | | | | | | | | | | | | | | | | | | | | | | | | | | | | | | | | | | | | | | | | | | | | | | | | | | | | | | | | | | | | | | | | | | | | | | | | | | | | | | | | | | | | | | | | | | | | | | | | | | | | | | | | | | | | | | | | | | | | | | | | | | | | | | | | | | | | | | | | | | | | | | | | | | | | | | | | | | | | | | | | | | | | | | | | | |
| 0 | 1 | | A ₇ | A ₆ | A ₅ | A ₄ | 0 | 0 | A ₁ | A ₀ | | | | | | | | | | | | | | A[7:6] | Select VBD as | | | | | | | | | | | | 00 | GS Transition Define A[1:0] | | | | | | | | | | | | 01 | Fix Level Define A [5:4] | | | | | | | | | | | | 10 | VCOM | | | | | | | | | | | | 11[POR] | HIZ | | | | | | | | | | | | A [5:4] Fix Level Setting for VBD | | | | | | | | | | | | | A[5:4] | VBD level | | | | | | | | | | | | 00[POR] | VSS | | | | | | | | | | | | 01 | VSH1 | | | | | | | | | | | | 10 | VSL | | | | | | | | | | | | 11 | VSH2 | | | | | | | | | | | | A[1:0] BW Transition setting for VBD | | | | | | | | | | | | | A[1:0] | VBD Transition | | | | | | | | | | | | 00 [POR] | LUT0 | | | | | | | | | | | | 01 | LUT1 | | | | | | | | | | | | 10 | LUT2 | | | | | | | | | | | | 11 | LUT3 | 0 | 0 | 44 | 0 | 1 | 0 | 0 | 0 | 1 | 0 | 0 | Set RAM X - address Start / End position | Specify the start/end positions of the window address in the X direction by an address unit A[9:0]: XSA[9:0], X Start, POR = 000h B[9:0]: XEA[9:0], X End, POR = 3BFh | 0 | 1 | | A ₇ | A ₆ | A ₅ | A ₄ | A ₃ | A ₂ | A ₁ | A ₀ | 0 | 1 | | - | - | - | - | - | - | A ₉ | A ₈ | 0 | 1 | | B ₇ | B ₆ | B ₅ | B ₄ | B ₃ | B ₂ | B ₁ | B ₀ | 0 | 1 | | - | - | - | - | - | - | B ₉ | B ₈ | 0 | 0 | 45 | 0 | 1 | 0 | 0 | 0 | 1 | 0 | 1 | Set Ram Y- address Start / End position | Specify the start/end positions of the window address in the Y direction by an address unit A[9:0]: YSA[9:0], Y Start, POR = 000h B[9:0]: YEA[9:0], Y End, POR = 2A7h | 0 | 1 | | A ₇ | A ₆ | A ₅ | A ₄ | A ₃ | A ₂ | A ₁ | A ₀ | 0 | 1 | | - | - | - | - | - | - | A ₉ | A ₈ | 0 | 1 | | B ₇ | B ₆ | B ₅ | B ₄ | B ₃ | B ₂ | B ₁ | B ₀ | 0 | 1 | | - | - | - | - | - | - | B ₉ | B ₈ | 0 | 0 | 4E | 0 | 1 | 0 | 0 | 1 | 1 | 1 | 0 | Set RAM X address counter | Make initial settings for the RAM X address in the address counter (AC) A[9:0]: 000h[POR] | 0 | 1 | | A ₇ | A ₆ | A ₅ | A ₄ | A ₃ | A ₂ | A ₁ | A ₀ | 0 | 1 | | - | - | - | - | - | - | A ₉ | A ₈ | 0 | 0 | 4F | 0 | 1 | 0 | 0 | 1 | 1 | 1 | 1 | Set RAM Y address counter | Make initial settings for the RAM Y address in the address counter (AC) A[9:0]: 000h[POR] | 0 | 1 | | A ₇ | A ₆ | A ₅ | A ₄ | A ₃ | A ₂ | A ₁ | A ₀ | 0 | 1 | | - | - | - | - | - | - | A ₉ | A ₈ | 0 | 1 | | A ₇ | A ₆ | A ₅ | A ₄ | A ₃ | A ₂ | A ₁ | A ₀ |
| | | | | | | | | | | | | | A[7:6] | Select VBD as | | | | | | | | | | | | | | | | | | | | | | | | | | | | | | | | | | | | | | | | | | | | | | | | | | | | | | | | | | | | | | | | | | | | | | | | | | | | | | | | | | | | | | | | | | | | | | | | | | | | | | | | | | | | | | | | | | | | | | | | | | | | | | | | | | | | | | | | | | | | | | | | | | | | | | | | | | | | | | | | | | | | | | | | | | | | | | | | | | | | | | | | | | | | | | | | | | | | | | | | | | | | | | | | | | | | | | | | | | | | | | | | | | | | | | | | | | | | | | | | | | | | | | | | | | | | | | | | | | | | | | | | | | | | | | | | | | | | | | | | | | | | | | | | | | | | | | | | | | | | | | | | | | | | | | | | | | | | | | | | | | | | | | | | | | | | | | | | | | | | | | | | | | | | | | | | | | | | | | | | | | | | | | | | | | | | | | | | | | | | | | | | | | | | | | | | | | | | | | | | | | | | | | | | | | | | | | |
| | | | | | | | | | | | | | 00 | GS Transition Define A[1:0] | | | | | | | | | | | | | | | | | | | | | | | | | | | | | | | | | | | | | | | | | | | | | | | | | | | | | | | | | | | | | | | | | | | | | | | | | | | | | | | | | | | | | | | | | | | | | | | | | | | | | | | | | | | | | | | | | | | | | | | | | | | | | | | | | | | | | | | | | | | | | | | | | | | | | | | | | | | | | | | | | | | | | | | | | | | | | | | | | | | | | | | | | | | | | | | | | | | | | | | | | | | | | | | | | | | | | | | | | | | | | | | | | | | | | | | | | | | | | | | | | | | | | | | | | | | | | | | | | | | | | | | | | | | | | | | | | | | | | | | | | | | | | | | | | | | | | | | | | | | | | | | | | | | | | | | | | | | | | | | | | | | | | | | | | | | | | | | | | | | | | | | | | | | | | | | | | | | | | | | | | | | | | | | | | | | | | | | | | | | | | | | | | | | | | | | | | | | | | | | | | | | | | | | | | | | | | | |
| | | | | | | | | | | | | | 01 | Fix Level Define A [5:4] | | | | | | | | | | | | | | | | | | | | | | | | | | | | | | | | | | | | | | | | | | | | | | | | | | | | | | | | | | | | | | | | | | | | | | | | | | | | | | | | | | | | | | | | | | | | | | | | | | | | | | | | | | | | | | | | | | | | | | | | | | | | | | | | | | | | | | | | | | | | | | | | | | | | | | | | | | | | | | | | | | | | | | | | | | | | | | | | | | | | | | | | | | | | | | | | | | | | | | | | | | | | | | | | | | | | | | | | | | | | | | | | | | | | | | | | | | | | | | | | | | | | | | | | | | | | | | | | | | | | | | | | | | | | | | | | | | | | | | | | | | | | | | | | | | | | | | | | | | | | | | | | | | | | | | | | | | | | | | | | | | | | | | | | | | | | | | | | | | | | | | | | | | | | | | | | | | | | | | | | | | | | | | | | | | | | | | | | | | | | | | | | | | | | | | | | | | | | | | | | | | | | | | | | | | | | | | |
| | | | | | | | | | | | | | 10 | VCOM | | | | | | | | | | | | | | | | | | | | | | | | | | | | | | | | | | | | | | | | | | | | | | | | | | | | | | | | | | | | | | | | | | | | | | | | | | | | | | | | | | | | | | | | | | | | | | | | | | | | | | | | | | | | | | | | | | | | | | | | | | | | | | | | | | | | | | | | | | | | | | | | | | | | | | | | | | | | | | | | | | | | | | | | | | | | | | | | | | | | | | | | | | | | | | | | | | | | | | | | | | | | | | | | | | | | | | | | | | | | | | | | | | | | | | | | | | | | | | | | | | | | | | | | | | | | | | | | | | | | | | | | | | | | | | | | | | | | | | | | | | | | | | | | | | | | | | | | | | | | | | | | | | | | | | | | | | | | | | | | | | | | | | | | | | | | | | | | | | | | | | | | | | | | | | | | | | | | | | | | | | | | | | | | | | | | | | | | | | | | | | | | | | | | | | | | | | | | | | | | | | | | | | | | | | | | | | |
| | | | | | | | | | | | | | 11[POR] | HIZ | | | | | | | | | | | | | | | | | | | | | | | | | | | | | | | | | | | | | | | | | | | | | | | | | | | | | | | | | | | | | | | | | | | | | | | | | | | | | | | | | | | | | | | | | | | | | | | | | | | | | | | | | | | | | | | | | | | | | | | | | | | | | | | | | | | | | | | | | | | | | | | | | | | | | | | | | | | | | | | | | | | | | | | | | | | | | | | | | | | | | | | | | | | | | | | | | | | | | | | | | | | | | | | | | | | | | | | | | | | | | | | | | | | | | | | | | | | | | | | | | | | | | | | | | | | | | | | | | | | | | | | | | | | | | | | | | | | | | | | | | | | | | | | | | | | | | | | | | | | | | | | | | | | | | | | | | | | | | | | | | | | | | | | | | | | | | | | | | | | | | | | | | | | | | | | | | | | | | | | | | | | | | | | | | | | | | | | | | | | | | | | | | | | | | | | | | | | | | | | | | | | | | | | | | | | | | | |
| | | | | | | | | | | | | | A [5:4] Fix Level Setting for VBD | | | | | | | | | | | | | | | | | | | | | | | | | | | | | | | | | | | | | | | | | | | | | | | | | | | | | | | | | | | | | | | | | | | | | | | | | | | | | | | | | | | | | | | | | | | | | | | | | | | | | | | | | | | | | | | | | | | | | | | | | | | | | | | | | | | | | | | | | | | | | | | | | | | | | | | | | | | | | | | | | | | | | | | | | | | | | | | | | | | | | | | | | | | | | | | | | | | | | | | | | | | | | | | | | | | | | | | | | | | | | | | | | | | | | | | | | | | | | | | | | | | | | | | | | | | | | | | | | | | | | | | | | | | | | | | | | | | | | | | | | | | | | | | | | | | | | | | | | | | | | | | | | | | | | | | | | | | | | | | | | | | | | | | | | | | | | | | | | | | | | | | | | | | | | | | | | | | | | | | | | | | | | | | | | | | | | | | | | | | | | | | | | | | | | | | | | | | | | | | | | | | | | | | | | | | | | | | |
| | | | | | | | | | | | | | A[5:4] | VBD level | | | | | | | | | | | | | | | | | | | | | | | | | | | | | | | | | | | | | | | | | | | | | | | | | | | | | | | | | | | | | | | | | | | | | | | | | | | | | | | | | | | | | | | | | | | | | | | | | | | | | | | | | | | | | | | | | | | | | | | | | | | | | | | | | | | | | | | | | | | | | | | | | | | | | | | | | | | | | | | | | | | | | | | | | | | | | | | | | | | | | | | | | | | | | | | | | | | | | | | | | | | | | | | | | | | | | | | | | | | | | | | | | | | | | | | | | | | | | | | | | | | | | | | | | | | | | | | | | | | | | | | | | | | | | | | | | | | | | | | | | | | | | | | | | | | | | | | | | | | | | | | | | | | | | | | | | | | | | | | | | | | | | | | | | | | | | | | | | | | | | | | | | | | | | | | | | | | | | | | | | | | | | | | | | | | | | | | | | | | | | | | | | | | | | | | | | | | | | | | | | | | | | | | | | | | | | | |
| | | | | | | | | | | | | | 00[POR] | VSS | | | | | | | | | | | | | | | | | | | | | | | | | | | | | | | | | | | | | | | | | | | | | | | | | | | | | | | | | | | | | | | | | | | | | | | | | | | | | | | | | | | | | | | | | | | | | | | | | | | | | | | | | | | | | | | | | | | | | | | | | | | | | | | | | | | | | | | | | | | | | | | | | | | | | | | | | | | | | | | | | | | | | | | | | | | | | | | | | | | | | | | | | | | | | | | | | | | | | | | | | | | | | | | | | | | | | | | | | | | | | | | | | | | | | | | | | | | | | | | | | | | | | | | | | | | | | | | | | | | | | | | | | | | | | | | | | | | | | | | | | | | | | | | | | | | | | | | | | | | | | | | | | | | | | | | | | | | | | | | | | | | | | | | | | | | | | | | | | | | | | | | | | | | | | | | | | | | | | | | | | | | | | | | | | | | | | | | | | | | | | | | | | | | | | | | | | | | | | | | | | | | | | | | | | | | | | | |
| | | | | | | | | | | | | | 01 | VSH1 | | | | | | | | | | | | | | | | | | | | | | | | | | | | | | | | | | | | | | | | | | | | | | | | | | | | | | | | | | | | | | | | | | | | | | | | | | | | | | | | | | | | | | | | | | | | | | | | | | | | | | | | | | | | | | | | | | | | | | | | | | | | | | | | | | | | | | | | | | | | | | | | | | | | | | | | | | | | | | | | | | | | | | | | | | | | | | | | | | | | | | | | | | | | | | | | | | | | | | | | | | | | | | | | | | | | | | | | | | | | | | | | | | | | | | | | | | | | | | | | | | | | | | | | | | | | | | | | | | | | | | | | | | | | | | | | | | | | | | | | | | | | | | | | | | | | | | | | | | | | | | | | | | | | | | | | | | | | | | | | | | | | | | | | | | | | | | | | | | | | | | | | | | | | | | | | | | | | | | | | | | | | | | | | | | | | | | | | | | | | | | | | | | | | | | | | | | | | | | | | | | | | | | | | | | | | | | |
| | | | | | | | | | | | | | 10 | VSL | | | | | | | | | | | | | | | | | | | | | | | | | | | | | | | | | | | | | | | | | | | | | | | | | | | | | | | | | | | | | | | | | | | | | | | | | | | | | | | | | | | | | | | | | | | | | | | | | | | | | | | | | | | | | | | | | | | | | | | | | | | | | | | | | | | | | | | | | | | | | | | | | | | | | | | | | | | | | | | | | | | | | | | | | | | | | | | | | | | | | | | | | | | | | | | | | | | | | | | | | | | | | | | | | | | | | | | | | | | | | | | | | | | | | | | | | | | | | | | | | | | | | | | | | | | | | | | | | | | | | | | | | | | | | | | | | | | | | | | | | | | | | | | | | | | | | | | | | | | | | | | | | | | | | | | | | | | | | | | | | | | | | | | | | | | | | | | | | | | | | | | | | | | | | | | | | | | | | | | | | | | | | | | | | | | | | | | | | | | | | | | | | | | | | | | | | | | | | | | | | | | | | | | | | | | | | | |
| | | | | | | | | | | | | | 11 | VSH2 | | | | | | | | | | | | | | | | | | | | | | | | | | | | | | | | | | | | | | | | | | | | | | | | | | | | | | | | | | | | | | | | | | | | | | | | | | | | | | | | | | | | | | | | | | | | | | | | | | | | | | | | | | | | | | | | | | | | | | | | | | | | | | | | | | | | | | | | | | | | | | | | | | | | | | | | | | | | | | | | | | | | | | | | | | | | | | | | | | | | | | | | | | | | | | | | | | | | | | | | | | | | | | | | | | | | | | | | | | | | | | | | | | | | | | | | | | | | | | | | | | | | | | | | | | | | | | | | | | | | | | | | | | | | | | | | | | | | | | | | | | | | | | | | | | | | | | | | | | | | | | | | | | | | | | | | | | | | | | | | | | | | | | | | | | | | | | | | | | | | | | | | | | | | | | | | | | | | | | | | | | | | | | | | | | | | | | | | | | | | | | | | | | | | | | | | | | | | | | | | | | | | | | | | | | | | | | |
| | | | | | | | | | | | A[1:0] BW Transition setting for VBD | | | | | | | | | | | | | | | | | | | | | | | | | | | | | | | | | | | | | | | | | | | | | | | | | | | | | | | | | | | | | | | | | | | | | | | | | | | | | | | | | | | | | | | | | | | | | | | | | | | | | | | | | | | | | | | | | | | | | | | | | | | | | | | | | | | | | | | | | | | | | | | | | | | | | | | | | | | | | | | | | | | | | | | | | | | | | | | | | | | | | | | | | | | | | | | | | | | | | | | | | | | | | | | | | | | | | | | | | | | | | | | | | | | | | | | | | | | | | | | | | | | | | | | | | | | | | | | | | | | | | | | | | | | | | | | | | | | | | | | | | | | | | | | | | | | | | | | | | | | | | | | | | | | | | | | | | | | | | | | | | | | | | | | | | | | | | | | | | | | | | | | | | | | | | | | | | | | | | | | | | | | | | | | | | | | | | | | | | | | | | | | | | | | | | | | | | | | | | | | | | | | | | | | | | | | | | | | | | |
| | | | | | | | | | | | A[1:0] | VBD Transition | | | | | | | | | | | | | | | | | | | | | | | | | | | | | | | | | | | | | | | | | | | | | | | | | | | | | | | | | | | | | | | | | | | | | | | | | | | | | | | | | | | | | | | | | | | | | | | | | | | | | | | | | | | | | | | | | | | | | | | | | | | | | | | | | | | | | | | | | | | | | | | | | | | | | | | | | | | | | | | | | | | | | | | | | | | | | | | | | | | | | | | | | | | | | | | | | | | | | | | | | | | | | | | | | | | | | | | | | | | | | | | | | | | | | | | | | | | | | | | | | | | | | | | | | | | | | | | | | | | | | | | | | | | | | | | | | | | | | | | | | | | | | | | | | | | | | | | | | | | | | | | | | | | | | | | | | | | | | | | | | | | | | | | | | | | | | | | | | | | | | | | | | | | | | | | | | | | | | | | | | | | | | | | | | | | | | | | | | | | | | | | | | | | | | | | | | | | | | | | | | | | | | | | | | | | | | | | | |
| | | | | | | | | | | | 00 [POR] | LUT0 | | | | | | | | | | | | | | | | | | | | | | | | | | | | | | | | | | | | | | | | | | | | | | | | | | | | | | | | | | | | | | | | | | | | | | | | | | | | | | | | | | | | | | | | | | | | | | | | | | | | | | | | | | | | | | | | | | | | | | | | | | | | | | | | | | | | | | | | | | | | | | | | | | | | | | | | | | | | | | | | | | | | | | | | | | | | | | | | | | | | | | | | | | | | | | | | | | | | | | | | | | | | | | | | | | | | | | | | | | | | | | | | | | | | | | | | | | | | | | | | | | | | | | | | | | | | | | | | | | | | | | | | | | | | | | | | | | | | | | | | | | | | | | | | | | | | | | | | | | | | | | | | | | | | | | | | | | | | | | | | | | | | | | | | | | | | | | | | | | | | | | | | | | | | | | | | | | | | | | | | | | | | | | | | | | | | | | | | | | | | | | | | | | | | | | | | | | | | | | | | | | | | | | | | | | | | | | | | |
| | | | | | | | | | | | 01 | LUT1 | | | | | | | | | | | | | | | | | | | | | | | | | | | | | | | | | | | | | | | | | | | | | | | | | | | | | | | | | | | | | | | | | | | | | | | | | | | | | | | | | | | | | | | | | | | | | | | | | | | | | | | | | | | | | | | | | | | | | | | | | | | | | | | | | | | | | | | | | | | | | | | | | | | | | | | | | | | | | | | | | | | | | | | | | | | | | | | | | | | | | | | | | | | | | | | | | | | | | | | | | | | | | | | | | | | | | | | | | | | | | | | | | | | | | | | | | | | | | | | | | | | | | | | | | | | | | | | | | | | | | | | | | | | | | | | | | | | | | | | | | | | | | | | | | | | | | | | | | | | | | | | | | | | | | | | | | | | | | | | | | | | | | | | | | | | | | | | | | | | | | | | | | | | | | | | | | | | | | | | | | | | | | | | | | | | | | | | | | | | | | | | | | | | | | | | | | | | | | | | | | | | | | | | | | | | | | | | | |
| | | | | | | | | | | | 10 | LUT2 | | | | | | | | | | | | | | | | | | | | | | | | | | | | | | | | | | | | | | | | | | | | | | | | | | | | | | | | | | | | | | | | | | | | | | | | | | | | | | | | | | | | | | | | | | | | | | | | | | | | | | | | | | | | | | | | | | | | | | | | | | | | | | | | | | | | | | | | | | | | | | | | | | | | | | | | | | | | | | | | | | | | | | | | | | | | | | | | | | | | | | | | | | | | | | | | | | | | | | | | | | | | | | | | | | | | | | | | | | | | | | | | | | | | | | | | | | | | | | | | | | | | | | | | | | | | | | | | | | | | | | | | | | | | | | | | | | | | | | | | | | | | | | | | | | | | | | | | | | | | | | | | | | | | | | | | | | | | | | | | | | | | | | | | | | | | | | | | | | | | | | | | | | | | | | | | | | | | | | | | | | | | | | | | | | | | | | | | | | | | | | | | | | | | | | | | | | | | | | | | | | | | | | | | | | | | | | | | |
| | | | | | | | | | | | 11 | LUT3 | | | | | | | | | | | | | | | | | | | | | | | | | | | | | | | | | | | | | | | | | | | | | | | | | | | | | | | | | | | | | | | | | | | | | | | | | | | | | | | | | | | | | | | | | | | | | | | | | | | | | | | | | | | | | | | | | | | | | | | | | | | | | | | | | | | | | | | | | | | | | | | | | | | | | | | | | | | | | | | | | | | | | | | | | | | | | | | | | | | | | | | | | | | | | | | | | | | | | | | | | | | | | | | | | | | | | | | | | | | | | | | | | | | | | | | | | | | | | | | | | | | | | | | | | | | | | | | | | | | | | | | | | | | | | | | | | | | | | | | | | | | | | | | | | | | | | | | | | | | | | | | | | | | | | | | | | | | | | | | | | | | | | | | | | | | | | | | | | | | | | | | | | | | | | | | | | | | | | | | | | | | | | | | | | | | | | | | | | | | | | | | | | | | | | | | | | | | | | | | | | | | | | | | | | | | | | | | | |
| 0 | 0 | 44 | 0 | 1 | 0 | 0 | 0 | 1 | 0 | 0 | Set RAM X - address Start / End position | Specify the start/end positions of the window address in the X direction by an address unit A[9:0]: XSA[9:0], X Start, POR = 000h B[9:0]: XEA[9:0], X End, POR = 3BFh | | | | | | | | | | | | | | | | | | | | | | | | | | | | | | | | | | | | | | | | | | | | | | | | | | | | | | | | | | | | | | | | | | | | | | | | | | | | | | | | | | | | | | | | | | | | | | | | | | | | | | | | | | | | | | | | | | | | | | | | | | | | | | | | | | | | | | | | | | | | | | | | | | | | | | | | | | | | | | | | | | | | | | | | | | | | | | | | | | | | | | | | | | | | | | | | | | | | | | | | | | | | | | | | | | | | | | | | | | | | | | | | | | | | | | | | | | | | | | | | | | | | | | | | | | | | | | | | | | | | | | | | | | | | | | | | | | | | | | | | | | | | | | | | | | | | | | | | | | | | | | | | | | | | | | | | | | | | | | | | | | | | | | | | | | | | | | | | | | | | | | | | | | | | | | | | | | | | | | | | | | | | | | | | | | | | | | | | | | | | | | | | | | | | | | | | | | | | | | | | | | | | | | | | | | | | | | | | |
| 0 | 1 | | A ₇ | A ₆ | A ₅ | A ₄ | A ₃ | A ₂ | A ₁ | A ₀ | | | | | | | | | | | | | | | | | | | | | | | | | | | | | | | | | | | | | | | | | | | | | | | | | | | | | | | | | | | | | | | | | | | | | | | | | | | | | | | | | | | | | | | | | | | | | | | | | | | | | | | | | | | | | | | | | | | | | | | | | | | | | | | | | | | | | | | | | | | | | | | | | | | | | | | | | | | | | | | | | | | | | | | | | | | | | | | | | | | | | | | | | | | | | | | | | | | | | | | | | | | | | | | | | | | | | | | | | | | | | | | | | | | | | | | | | | | | | | | | | | | | | | | | | | | | | | | | | | | | | | | | | | | | | | | | | | | | | | | | | | | | | | | | | | | | | | | | | | | | | | | | | | | | | | | | | | | | | | | | | | | | | | | | | | | | | | | | | | | | | | | | | | | | | | | | | | | | | | | | | | | | | | | | | | | | | | | | | | | | | | | | | | | | | | | | | | | | | | | | | | | | | | | | | | | | | | | | | | |
| 0 | 1 | | - | - | - | - | - | - | A ₉ | A ₈ | | | | | | | | | | | | | | | | | | | | | | | | | | | | | | | | | | | | | | | | | | | | | | | | | | | | | | | | | | | | | | | | | | | | | | | | | | | | | | | | | | | | | | | | | | | | | | | | | | | | | | | | | | | | | | | | | | | | | | | | | | | | | | | | | | | | | | | | | | | | | | | | | | | | | | | | | | | | | | | | | | | | | | | | | | | | | | | | | | | | | | | | | | | | | | | | | | | | | | | | | | | | | | | | | | | | | | | | | | | | | | | | | | | | | | | | | | | | | | | | | | | | | | | | | | | | | | | | | | | | | | | | | | | | | | | | | | | | | | | | | | | | | | | | | | | | | | | | | | | | | | | | | | | | | | | | | | | | | | | | | | | | | | | | | | | | | | | | | | | | | | | | | | | | | | | | | | | | | | | | | | | | | | | | | | | | | | | | | | | | | | | | | | | | | | | | | | | | | | | | | | | | | | | | | | | | | | | | | | |
| 0 | 1 | | B ₇ | B ₆ | B ₅ | B ₄ | B ₃ | B ₂ | B ₁ | B ₀ | | | | | | | | | | | | | | | | | | | | | | | | | | | | | | | | | | | | | | | | | | | | | | | | | | | | | | | | | | | | | | | | | | | | | | | | | | | | | | | | | | | | | | | | | | | | | | | | | | | | | | | | | | | | | | | | | | | | | | | | | | | | | | | | | | | | | | | | | | | | | | | | | | | | | | | | | | | | | | | | | | | | | | | | | | | | | | | | | | | | | | | | | | | | | | | | | | | | | | | | | | | | | | | | | | | | | | | | | | | | | | | | | | | | | | | | | | | | | | | | | | | | | | | | | | | | | | | | | | | | | | | | | | | | | | | | | | | | | | | | | | | | | | | | | | | | | | | | | | | | | | | | | | | | | | | | | | | | | | | | | | | | | | | | | | | | | | | | | | | | | | | | | | | | | | | | | | | | | | | | | | | | | | | | | | | | | | | | | | | | | | | | | | | | | | | | | | | | | | | | | | | | | | | | | | | | | | | | | | |
| 0 | 1 | | - | - | - | - | - | - | B ₉ | B ₈ | | | | | | | | | | | | | | | | | | | | | | | | | | | | | | | | | | | | | | | | | | | | | | | | | | | | | | | | | | | | | | | | | | | | | | | | | | | | | | | | | | | | | | | | | | | | | | | | | | | | | | | | | | | | | | | | | | | | | | | | | | | | | | | | | | | | | | | | | | | | | | | | | | | | | | | | | | | | | | | | | | | | | | | | | | | | | | | | | | | | | | | | | | | | | | | | | | | | | | | | | | | | | | | | | | | | | | | | | | | | | | | | | | | | | | | | | | | | | | | | | | | | | | | | | | | | | | | | | | | | | | | | | | | | | | | | | | | | | | | | | | | | | | | | | | | | | | | | | | | | | | | | | | | | | | | | | | | | | | | | | | | | | | | | | | | | | | | | | | | | | | | | | | | | | | | | | | | | | | | | | | | | | | | | | | | | | | | | | | | | | | | | | | | | | | | | | | | | | | | | | | | | | | | | | | | | | | | | | | |
| 0 | 0 | 45 | 0 | 1 | 0 | 0 | 0 | 1 | 0 | 1 | Set Ram Y- address Start / End position | Specify the start/end positions of the window address in the Y direction by an address unit A[9:0]: YSA[9:0], Y Start, POR = 000h B[9:0]: YEA[9:0], Y End, POR = 2A7h | | | | | | | | | | | | | | | | | | | | | | | | | | | | | | | | | | | | | | | | | | | | | | | | | | | | | | | | | | | | | | | | | | | | | | | | | | | | | | | | | | | | | | | | | | | | | | | | | | | | | | | | | | | | | | | | | | | | | | | | | | | | | | | | | | | | | | | | | | | | | | | | | | | | | | | | | | | | | | | | | | | | | | | | | | | | | | | | | | | | | | | | | | | | | | | | | | | | | | | | | | | | | | | | | | | | | | | | | | | | | | | | | | | | | | | | | | | | | | | | | | | | | | | | | | | | | | | | | | | | | | | | | | | | | | | | | | | | | | | | | | | | | | | | | | | | | | | | | | | | | | | | | | | | | | | | | | | | | | | | | | | | | | | | | | | | | | | | | | | | | | | | | | | | | | | | | | | | | | | | | | | | | | | | | | | | | | | | | | | | | | | | | | | | | | | | | | | | | | | | | | | | | | | | | | | | | | | | |
| 0 | 1 | | A ₇ | A ₆ | A ₅ | A ₄ | A ₃ | A ₂ | A ₁ | A ₀ | | | | | | | | | | | | | | | | | | | | | | | | | | | | | | | | | | | | | | | | | | | | | | | | | | | | | | | | | | | | | | | | | | | | | | | | | | | | | | | | | | | | | | | | | | | | | | | | | | | | | | | | | | | | | | | | | | | | | | | | | | | | | | | | | | | | | | | | | | | | | | | | | | | | | | | | | | | | | | | | | | | | | | | | | | | | | | | | | | | | | | | | | | | | | | | | | | | | | | | | | | | | | | | | | | | | | | | | | | | | | | | | | | | | | | | | | | | | | | | | | | | | | | | | | | | | | | | | | | | | | | | | | | | | | | | | | | | | | | | | | | | | | | | | | | | | | | | | | | | | | | | | | | | | | | | | | | | | | | | | | | | | | | | | | | | | | | | | | | | | | | | | | | | | | | | | | | | | | | | | | | | | | | | | | | | | | | | | | | | | | | | | | | | | | | | | | | | | | | | | | | | | | | | | | | | | | | | | | | |
| 0 | 1 | | - | - | - | - | - | - | A ₉ | A ₈ | | | | | | | | | | | | | | | | | | | | | | | | | | | | | | | | | | | | | | | | | | | | | | | | | | | | | | | | | | | | | | | | | | | | | | | | | | | | | | | | | | | | | | | | | | | | | | | | | | | | | | | | | | | | | | | | | | | | | | | | | | | | | | | | | | | | | | | | | | | | | | | | | | | | | | | | | | | | | | | | | | | | | | | | | | | | | | | | | | | | | | | | | | | | | | | | | | | | | | | | | | | | | | | | | | | | | | | | | | | | | | | | | | | | | | | | | | | | | | | | | | | | | | | | | | | | | | | | | | | | | | | | | | | | | | | | | | | | | | | | | | | | | | | | | | | | | | | | | | | | | | | | | | | | | | | | | | | | | | | | | | | | | | | | | | | | | | | | | | | | | | | | | | | | | | | | | | | | | | | | | | | | | | | | | | | | | | | | | | | | | | | | | | | | | | | | | | | | | | | | | | | | | | | | | | | | | | | | | | |
| 0 | 1 | | B ₇ | B ₆ | B ₅ | B ₄ | B ₃ | B ₂ | B ₁ | B ₀ | | | | | | | | | | | | | | | | | | | | | | | | | | | | | | | | | | | | | | | | | | | | | | | | | | | | | | | | | | | | | | | | | | | | | | | | | | | | | | | | | | | | | | | | | | | | | | | | | | | | | | | | | | | | | | | | | | | | | | | | | | | | | | | | | | | | | | | | | | | | | | | | | | | | | | | | | | | | | | | | | | | | | | | | | | | | | | | | | | | | | | | | | | | | | | | | | | | | | | | | | | | | | | | | | | | | | | | | | | | | | | | | | | | | | | | | | | | | | | | | | | | | | | | | | | | | | | | | | | | | | | | | | | | | | | | | | | | | | | | | | | | | | | | | | | | | | | | | | | | | | | | | | | | | | | | | | | | | | | | | | | | | | | | | | | | | | | | | | | | | | | | | | | | | | | | | | | | | | | | | | | | | | | | | | | | | | | | | | | | | | | | | | | | | | | | | | | | | | | | | | | | | | | | | | | | | | | | | | | |
| 0 | 1 | | - | - | - | - | - | - | B ₉ | B ₈ | | | | | | | | | | | | | | | | | | | | | | | | | | | | | | | | | | | | | | | | | | | | | | | | | | | | | | | | | | | | | | | | | | | | | | | | | | | | | | | | | | | | | | | | | | | | | | | | | | | | | | | | | | | | | | | | | | | | | | | | | | | | | | | | | | | | | | | | | | | | | | | | | | | | | | | | | | | | | | | | | | | | | | | | | | | | | | | | | | | | | | | | | | | | | | | | | | | | | | | | | | | | | | | | | | | | | | | | | | | | | | | | | | | | | | | | | | | | | | | | | | | | | | | | | | | | | | | | | | | | | | | | | | | | | | | | | | | | | | | | | | | | | | | | | | | | | | | | | | | | | | | | | | | | | | | | | | | | | | | | | | | | | | | | | | | | | | | | | | | | | | | | | | | | | | | | | | | | | | | | | | | | | | | | | | | | | | | | | | | | | | | | | | | | | | | | | | | | | | | | | | | | | | | | | | | | | | | | | | |
| 0 | 0 | 4E | 0 | 1 | 0 | 0 | 1 | 1 | 1 | 0 | Set RAM X address counter | Make initial settings for the RAM X address in the address counter (AC) A[9:0]: 000h[POR] | | | | | | | | | | | | | | | | | | | | | | | | | | | | | | | | | | | | | | | | | | | | | | | | | | | | | | | | | | | | | | | | | | | | | | | | | | | | | | | | | | | | | | | | | | | | | | | | | | | | | | | | | | | | | | | | | | | | | | | | | | | | | | | | | | | | | | | | | | | | | | | | | | | | | | | | | | | | | | | | | | | | | | | | | | | | | | | | | | | | | | | | | | | | | | | | | | | | | | | | | | | | | | | | | | | | | | | | | | | | | | | | | | | | | | | | | | | | | | | | | | | | | | | | | | | | | | | | | | | | | | | | | | | | | | | | | | | | | | | | | | | | | | | | | | | | | | | | | | | | | | | | | | | | | | | | | | | | | | | | | | | | | | | | | | | | | | | | | | | | | | | | | | | | | | | | | | | | | | | | | | | | | | | | | | | | | | | | | | | | | | | | | | | | | | | | | | | | | | | | | | | | | | | | | | | | | | | | |
| 0 | 1 | | A ₇ | A ₆ | A ₅ | A ₄ | A ₃ | A ₂ | A ₁ | A ₀ | | | | | | | | | | | | | | | | | | | | | | | | | | | | | | | | | | | | | | | | | | | | | | | | | | | | | | | | | | | | | | | | | | | | | | | | | | | | | | | | | | | | | | | | | | | | | | | | | | | | | | | | | | | | | | | | | | | | | | | | | | | | | | | | | | | | | | | | | | | | | | | | | | | | | | | | | | | | | | | | | | | | | | | | | | | | | | | | | | | | | | | | | | | | | | | | | | | | | | | | | | | | | | | | | | | | | | | | | | | | | | | | | | | | | | | | | | | | | | | | | | | | | | | | | | | | | | | | | | | | | | | | | | | | | | | | | | | | | | | | | | | | | | | | | | | | | | | | | | | | | | | | | | | | | | | | | | | | | | | | | | | | | | | | | | | | | | | | | | | | | | | | | | | | | | | | | | | | | | | | | | | | | | | | | | | | | | | | | | | | | | | | | | | | | | | | | | | | | | | | | | | | | | | | | | | | | | | | | | |
| 0 | 1 | | - | - | - | - | - | - | A ₉ | A ₈ | | | | | | | | | | | | | | | | | | | | | | | | | | | | | | | | | | | | | | | | | | | | | | | | | | | | | | | | | | | | | | | | | | | | | | | | | | | | | | | | | | | | | | | | | | | | | | | | | | | | | | | | | | | | | | | | | | | | | | | | | | | | | | | | | | | | | | | | | | | | | | | | | | | | | | | | | | | | | | | | | | | | | | | | | | | | | | | | | | | | | | | | | | | | | | | | | | | | | | | | | | | | | | | | | | | | | | | | | | | | | | | | | | | | | | | | | | | | | | | | | | | | | | | | | | | | | | | | | | | | | | | | | | | | | | | | | | | | | | | | | | | | | | | | | | | | | | | | | | | | | | | | | | | | | | | | | | | | | | | | | | | | | | | | | | | | | | | | | | | | | | | | | | | | | | | | | | | | | | | | | | | | | | | | | | | | | | | | | | | | | | | | | | | | | | | | | | | | | | | | | | | | | | | | | | | | | | | | | | |
| 0 | 0 | 4F | 0 | 1 | 0 | 0 | 1 | 1 | 1 | 1 | Set RAM Y address counter | Make initial settings for the RAM Y address in the address counter (AC) A[9:0]: 000h[POR] | | | | | | | | | | | | | | | | | | | | | | | | | | | | | | | | | | | | | | | | | | | | | | | | | | | | | | | | | | | | | | | | | | | | | | | | | | | | | | | | | | | | | | | | | | | | | | | | | | | | | | | | | | | | | | | | | | | | | | | | | | | | | | | | | | | | | | | | | | | | | | | | | | | | | | | | | | | | | | | | | | | | | | | | | | | | | | | | | | | | | | | | | | | | | | | | | | | | | | | | | | | | | | | | | | | | | | | | | | | | | | | | | | | | | | | | | | | | | | | | | | | | | | | | | | | | | | | | | | | | | | | | | | | | | | | | | | | | | | | | | | | | | | | | | | | | | | | | | | | | | | | | | | | | | | | | | | | | | | | | | | | | | | | | | | | | | | | | | | | | | | | | | | | | | | | | | | | | | | | | | | | | | | | | | | | | | | | | | | | | | | | | | | | | | | | | | | | | | | | | | | | | | | | | | | | | | | | | |
| 0 | 1 | | A ₇ | A ₆ | A ₅ | A ₄ | A ₃ | A ₂ | A ₁ | A ₀ | | | | | | | | | | | | | | | | | | | | | | | | | | | | | | | | | | | | | | | | | | | | | | | | | | | | | | | | | | | | | | | | | | | | | | | | | | | | | | | | | | | | | | | | | | | | | | | | | | | | | | | | | | | | | | | | | | | | | | | | | | | | | | | | | | | | | | | | | | | | | | | | | | | | | | | | | | | | | | | | | | | | | | | | | | | | | | | | | | | | | | | | | | | | | | | | | | | | | | | | | | | | | | | | | | | | | | | | | | | | | | | | | | | | | | | | | | | | | | | | | | | | | | | | | | | | | | | | | | | | | | | | | | | | | | | | | | | | | | | | | | | | | | | | | | | | | | | | | | | | | | | | | | | | | | | | | | | | | | | | | | | | | | | | | | | | | | | | | | | | | | | | | | | | | | | | | | | | | | | | | | | | | | | | | | | | | | | | | | | | | | | | | | | | | | | | | | | | | | | | | | | | | | | | | | | | | | | | | | |
| 0 | 1 | | - | - | - | - | - | - | A ₉ | A ₈ | | | | | | | | | | | | | | | | | | | | | | | | | | | | | | | | | | | | | | | | | | | | | | | | | | | | | | | | | | | | | | | | | | | | | | | | | | | | | | | | | | | | | | | | | | | | | | | | | | | | | | | | | | | | | | | | | | | | | | | | | | | | | | | | | | | | | | | | | | | | | | | | | | | | | | | | | | | | | | | | | | | | | | | | | | | | | | | | | | | | | | | | | | | | | | | | | | | | | | | | | | | | | | | | | | | | | | | | | | | | | | | | | | | | | | | | | | | | | | | | | | | | | | | | | | | | | | | | | | | | | | | | | | | | | | | | | | | | | | | | | | | | | | | | | | | | | | | | | | | | | | | | | | | | | | | | | | | | | | | | | | | | | | | | | | | | | | | | | | | | | | | | | | | | | | | | | | | | | | | | | | | | | | | | | | | | | | | | | | | | | | | | | | | | | | | | | | | | | | | | | | | | | | | | | | | | | | | | | | |
| 0 | 1 | | A ₇ | A ₆ | A ₅ | A ₄ | A ₃ | A ₂ | A ₁ | A ₀ | | | | | | | | | | | | | | | | | | | | | | | | | | | | | | | | | | | | | | | | | | | | | | | | | | | | | | | | | | | | | | | | | | | | | | | | | | | | | | | | | | | | | | | | | | | | | | | | | | | | | | | | | | | | | | | | | | | | | | | | | | | | | | | | | | | | | | | | | | | | | | | | | | | | | | | | | | | | | | | | | | | | | | | | | | | | | | | | | | | | | | | | | | | | | | | | | | | | | | | | | | | | | | | | | | | | | | | | | | | | | | | | | | | | | | | | | | | | | | | | | | | | | | | | | | | | | | | | | | | | | | | | | | | | | | | | | | | | | | | | | | | | | | | | | | | | | | | | | | | | | | | | | | | | | | | | | | | | | | | | | | | | | | | | | | | | | | | | | | | | | | | | | | | | | | | | | | | | | | | | | | | | | | | | | | | | | | | | | | | | | | | | | | | | | | | | | | | | | | | | | | | | | | | | | | | | | | | | | | |

| | | | |
|------------------|---------|-----------------------|-------------------------|
| DATE JUL.17.2019 | Version | 1.0 | TECHNICAL SPECIFICATION |
| LCM | YES | YMS960680-1330AAAMFGN | Page 16 of 25 |

8. Optical Specifications

Measurements are made with that the illumination is under an angle of 45 degree, the detection is perpendicular unless otherwise specified

| Symbol | Parameter | Conditions | Min | Typ. | Max | Units | Notes |
|----------|--------------------|------------|-----|------------------------|-----|-------|-------|
| R | White Reflectivity | White | 30 | 35 | - | % | 8-1 |
| CR | Contrast Ratio | indoor | 8:1 | | - | | 8-2 |
| GN | 2Grey Level | - | - | $DS+(WS-DS)*n(m-1)$ | | | 8-3 |
| T update | Image update time | at 23 °C | - | 25 | - | sec | |
| Life | | Topr | | 1000000times or 5years | | | |

Notes: 8-1. Luminance meter: Eye-One Pro Spectrophotometer.

8-2. CR=Surface Reflectance with all white pixel/Surface Reflectance with all black pixels.

8-3 WS: White state, DS: Dark state

9. Handling, Safety and Environment Requirements

Warning

The display glass may break when it is dropped or bumped on a hard surface. Handle with care. Should the display break, do not touch the electrophoretic material. In case of contact with electrophoretic material, wash with water and soap.

Caution

The display module should not be exposed to harmful gases, such as acid and alkali gases, which corrode electronic components. Disassembling the display module.

Disassembling the display module can cause permanent damage and invalidates the warranty agreements.

Observe general precautions that are common to handling delicate electronic components. The glass can break and front surfaces can easily be damaged. Moreover the display is sensitive to static electricity and other rough environmental conditions.

| Data sheet status | |
|---|--|
| Product specification | This data sheet contains final product specifications. |
| Limiting values | |
| Limiting values given are in accordance with the Absolute Maximum Rating System (IEC 134). Stress above one or more of the limiting values may cause permanent damage to the device. These are stress ratings only and operation of the device at these or at any other conditions above those given in the Characteristics sections of the specification is not implied. Exposure to limiting values for extended periods may affect device reliability. | |
| Application information | |
| Where application information is given, it is advisory and does not form part of the specification. | |

| | | | |
|------------------|---------|-----------------------|-------------------------|
| DATE JUL.17.2019 | Version | 1.0 | TECHNICAL SPECIFICATION |
| LCM | YES | YMS960680-1330AAAMFGN | Page 17 of 25 |

10. Reliability test

| NO | Test Items | Test condition |
|----|---|--|
| 1 | Low-Temperature Storage | T = -25°C, 240 h Test in white pattern |
| 2 | High-Temperature Storage | T = +70°C, RH=40% ,240h Test in white pattern |
| 3 | High-Temperature Operation | T = +50°C, RH = 30% ,240h |
| 4 | Low-Temperature Operation | 0°C, 240h |
| 5 | High-Temperature, High-Humidity Operation | T=+40°C, RH=90%,168h |
| 6 | High Temperature, High Humidity Storage | T=+60°C, RH=80%,240h Test in white pattern |
| 7 | Temperature Cycle | 1 cycle:[-25°C 30min]→[+70 °C 30 min] : 100 cycles Test in white pattern |
| 8 | UV exposure Resistance | 765W/m ² for 168hrs,40 °C Test in white pattern |
| 9 | ESD Gun | Air+/-15KV;Contact+/-8KV (Test finished product shell, not display only) Air+/-8KV;Contact+/-6KV (Naked EPD display, no including IC and FPC area) Air+/-4KV;Contact+/-2KV (Naked EPD display, including IC and FPC area) |

Note: Put in normal temperature for 1hour after test finished, display performance is ok.

| | | | |
|------------------|----------------|-----------------------|-------------------------|
| DATE JUL.17.2019 | Version | 1.0 | TECHNICAL SPECIFICATION |
| LCM | YES | YMS960680-1330AAAMFGN | Page 18 of 25 |

11. Block Diagram

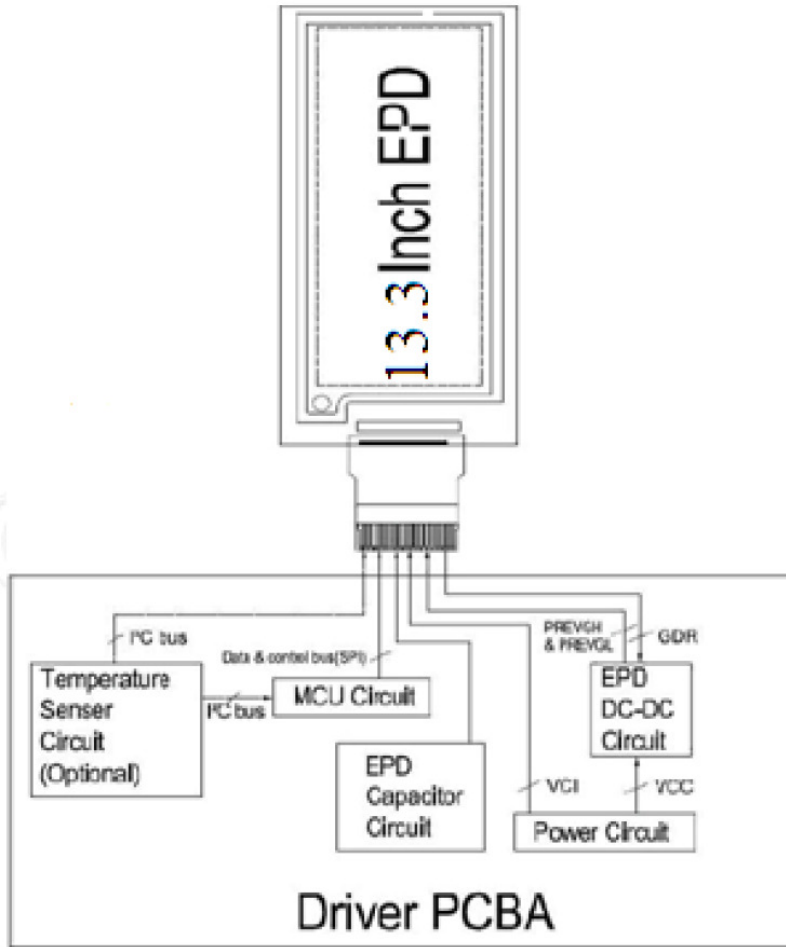

12. Typical Application Circuit with SPI Interface

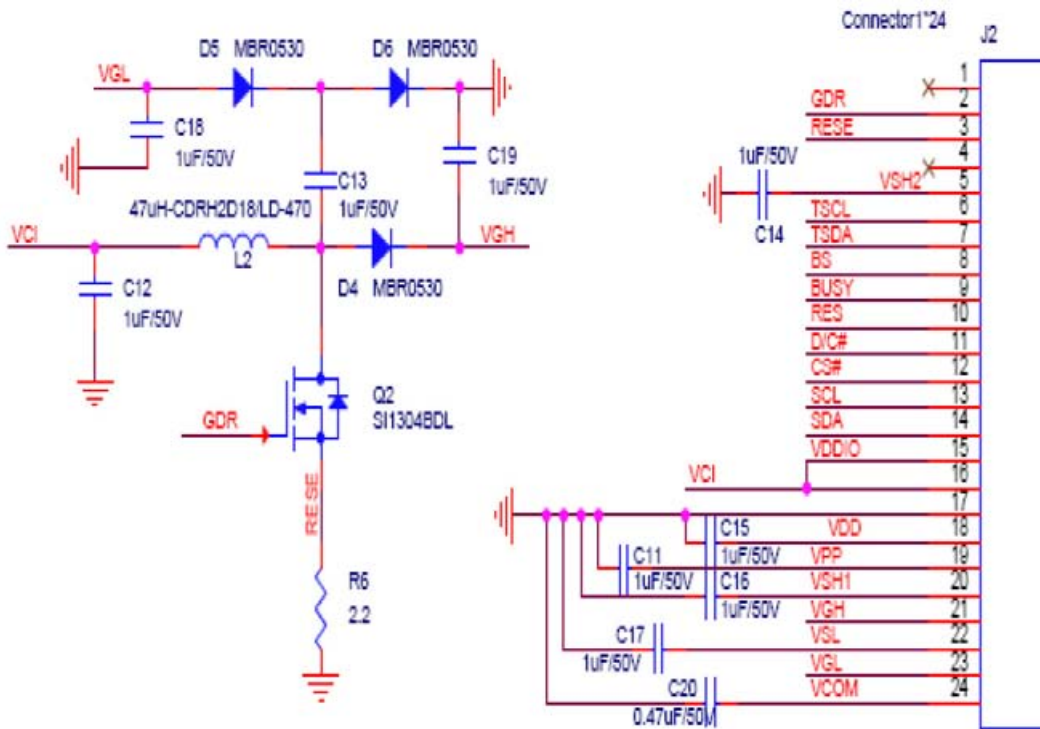

| | | | |
|------------------|---------|-----------------------|-------------------------|
| DATE JUL.17.2019 | Version | 1.0 | TECHNICAL SPECIFICATION |
| LCM | YES | YMS960680-1330AAAMFGN | Page 19 of 25 |

13. Typical Operating Sequence

13.1 Normal Operation Flow

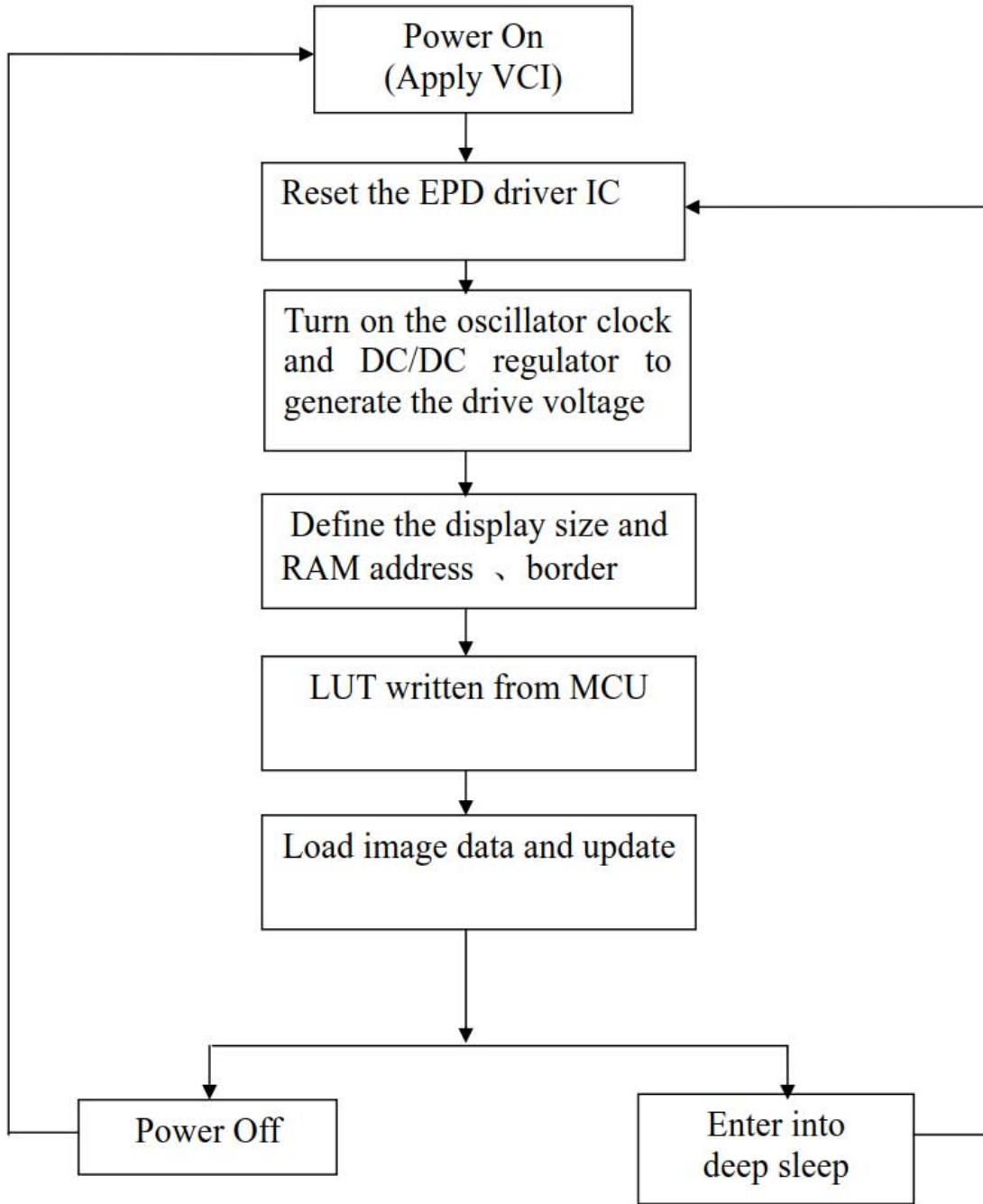

| | | | |
|------------------|----------------|-----------------------|-------------------------|
| DATE JUL.17.2019 | Version | 1.0 | TECHNICAL SPECIFICATION |
| LCM | YES | YMS960680-1330AAAMFGN | Page 20 of 25 |

13.2 Normal Operation Reference Program Code

| ACTION | VALUE/DATA | COMMENT |
|--------------------------|--------------------------|--|
| POWER ON | | |
| delay | 10ms | |
| PIN CONFIG | | |
| RESE# | high | Hardware reset |
| delay | 200us | |
| RESE# | low | |
| delay | 200us | |
| Read busy pin | | Wait for busy low |
| Command 0x12 | | Software reset |
| Read busy pin | | Wait for busy low |
| Command 0x01 | Data 0xA7 0x02 0x00 | Set display size and driver output control |
| Command 0x11 | Data 0x01 | Ram data entry mode |
| Command 0x44 | Data 0x00 0x00 0xBF 0x03 | Set Ram X address |
| Command 0x45 | Data 0xA7 0x02 0x00 0x00 | Set Ram Y address |
| Command 0x3C | Data 0x01 | Set border |
| SET VOLTAGE AND LOAD LUT | | |
| Command 0x2C | Data 0x50 | Set VCOM value |
| Command 0x03 | Data 0x17 | Gate voltage setting |
| Command 0x04 | Data 0x41 0xB0 0x32 | Source voltage setting |
| Command 0x32 | Write 106bytes LUT | Load LUT |
| LOAD IMAGE AND UPDATE | | |
| Command 0x4E | Data 0x00 0x00 | Set Ram X address counter |
| Command 0x4F | Data 0xA7 0x02 | Set Ram Y address counter |
| Command 0x24 | 81600 bytes | Load BW image (128/8*296) |
| Command 0x4E | Data 0x00 0x00 | Set Ram X address counter |
| Command 0x4F | Data 0xA7 0x02 | Set Ram Y address counter |
| Command 0x26 | 81600 bytes | Load RED image (128/8*296) |
| Command 0x22 | Data 0xC7 | Image update |
| Command 0x20 | | |
| Read busy pin | | Wait for busy low |
| Command 0x10 | Data 0x01 | Enter deep sleep mode |
| POWER OFF | | |

14. Part Number Definition

TBD

| | | | |
|------------------|----------------|-----------------------|-------------------------|
| DATE JUL.17.2019 | Version | 1.0 | TECHNICAL SPECIFICATION |
| LCM | YES | YMS960680-1330AAAMFGN | Page 21 of 25 |

15. Inspection condition

15.1 Environment

Temperature: $25 \pm 3^{\circ}\text{C}$

Humidity: $55 \pm 10\% \text{RH}$

15.2 Illuminance

Brightness: 1200~1500LUX; distance: 20-30CM; Angle: Relate 30° surround.

15.3 Inspect method

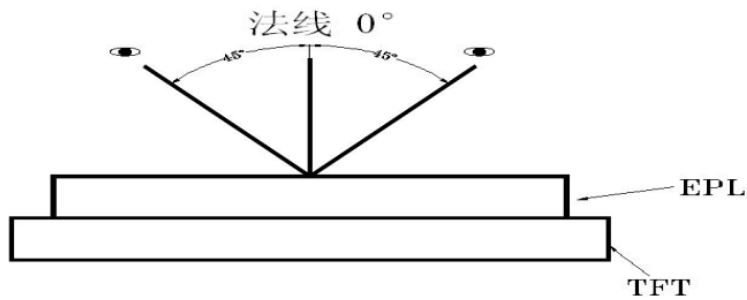

15.4 Display area

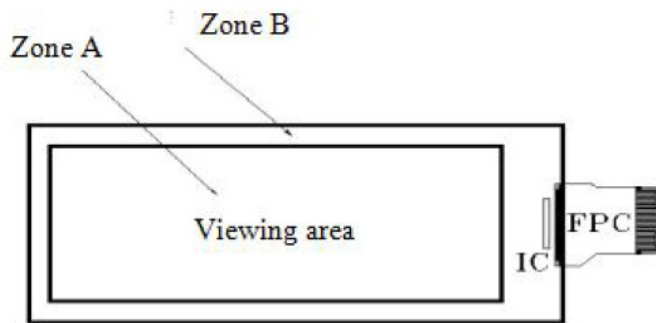

| | | | |
|------------------|----------------|-----------------------|-------------------------|
| DATE JUL.17.2019 | Version | 1.0 | TECHNICAL SPECIFICATION |
| LCM | YES | YMS960680-1330AAAMFGN | Page 22 of 25 |

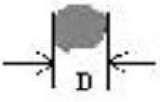
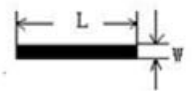

15.5 Inspection standard

15.5.1 Electric inspection standard

| NO. | Item | Standard | Defect level | Method | Scope |
|-----|--|--|--------------|----------------------------|------------------|
| 1 | Display | Display complete Display uniform | MA | Visual inspection | |
| 2 | Black/White spots |  $D \leq 0.25\text{mm}$, Allowed $0.25\text{mm} < D \leq 0.4\text{mm}$, $N \leq 3$, and Distance $\geq 5\text{mm}$ $0.4\text{mm} < D$ Not Allow | MI | | |
| 3 | Black/White spots (No switch) |  $L \leq 0.6\text{mm}$, $W \leq 0.2\text{mm}$, $N \leq 1$ $L \leq 2.0\text{mm}$, $W > 0.2\text{mm}$, Not Allow $L > 0.6\text{mm}$, Not Allow | | Visual/ Inspection card | Zone A |
| 4 | Ghost image | Allowed in switching process | MI | Visual inspection | |
| 5 | Flash spots/ Larger FPL size | Flash spots in switching, Allowed FPL size larger than viewing area, Allowed | MI | Visual/ Inspection card | Zone A Zone B |
| 6 | Display wrong/Missing | All appointed displays are showed correct | MA | Visual inspection | Zone A |
| 6 | Short circuit/ Circuit break/ Display abnormal | Not Allow | | | |

| | | | |
|------------------|----------------|-----------------------|-------------------------|
| DATE JUL.17.2019 | Version | 1.0 | TECHNICAL SPECIFICATION |
| LCM | YES | YMS960680-1330AAAMFGN | Page 23 of 25 |

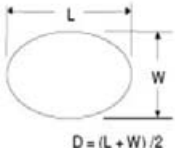
15.5.2 Appearance inspection standard

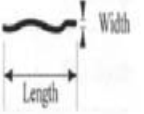
| NO. | Item | Standard | Defect level | Method | Scope |
|-----|---|--|--------------|------------------------|------------------|
| 1 | B/W spots /Bubble/ Foreign bodies/ Dents |  <p>$D = (L+W)/2$ $D \leq 0.25\text{mm}$, Allowed $0.25\text{mm} < D \leq 0.4\text{mm}$, $N \leq 3$ $D > 0.4\text{mm}$, Not Allow</p> | MI | Visual inspection | Zone A |
| 2 | Glass crack | Not Allow | MA | Visual / Microscope | Zone A Zone B |
| 3 | Dirty | Allowed if can be removed | MI | | Zone A Zone B |
| 4 | Chips/Scratch/ Edge crown |  <p>$X \leq 3\text{mm}, Y \leq 0.5\text{mm}$</p>  <p>$2\text{mm} \leq X$ or $2\text{mm} \leq Y$ Allow</p>  <p>$W \leq 0.1\text{mm}, L \leq 5\text{mm}, n \leq 2$ Edge crown: $X \leq 0.3\text{mm}, Y \leq 3\text{mm}$</p> | MI | Visual / Microscope | Zone A Zone B |

| | | | |
|------------------|----------------|-----------------------|-------------------------|
| DATE JUL.17.2019 | Version | 1.0 | TECHNICAL SPECIFICATION |
| LCM | YES | YMS960680-1330AAAMFGN | Page 24 of 25 |

| | | | | | |
|---|---|--|----|------------------------|--------|
| 5 | Substrate color difference | Allowed | | | |
| 6 | FPC broken/ Goldfingers oxidation/ scratch |  Not Allow | MA | Visual / Microscope | Zone B |
| 7 | PCB damaged/ Poor welding/ Curl | PCB (Circuit area) damaged Not Allow PCB Poor welding Not Allow PCB Curl ≤ 1% | MI | Visual / Ruler | Zone B |
| 8 | Edge Adhesives height/FPL/ Edge adhesives bubble | Edge Adhesives height ≤ Display surface Edge adhesives seep in ≤ 1/2 Margin width FPL tolerance ± 0.3mm Edge adhesives bubble: bubble Width ≤ 1/2 Margin width; Length ≤ 0.5mm. n ≤ 3 | | | |
| 9 | Protect film | Surface scratch but not effect protect function, Allowed | | Visual Inspection | |

16. Packaging
TBD

| | | | |
|------------------|----------------|-----------------------|-------------------------|
| DATE JUL.17.2019 | Version | 1.0 | TECHNICAL SPECIFICATION |
| LCM | YES | YMS960680-1330AAAMFGN | Page 25 of 25 |